

General Description

TD8228 is a high efficiency, current-mode control Boost DC to DC regulator with an integrated 120mΩ $R_{DS(ON)}$ N-channel MOSFET. The fixed 1MHz switching frequency and internal compensation reduce external component count and save the PCB space. The build-in internal soft start circuitry minimizes the inrush current at start-up.

Features

- Wide input range:2-6V
- 1MHz switching frequency
- Minimum on time: 100ns typical
- Minimum off time: 100ns typical
- Max output voltage: 6V
- Low $R_{DS(ON)}$: 120mΩ
- Adjustable Over Current Protection:0.5~4.5A
- RoHS Compliant and Halogen Free
- Compact package: SOT23-6

Applications

- Cell Phone and Smart Phone
- PDA, PMP, MP3
- Digital Camera

Package Types



SOT23-6

Figure 1. Package Types of TD8228

Pin Configurations

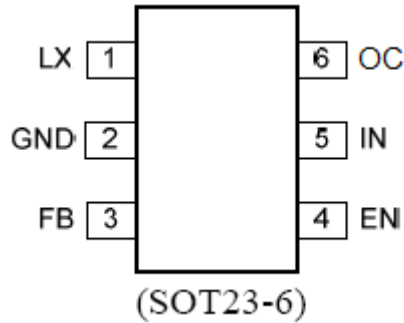
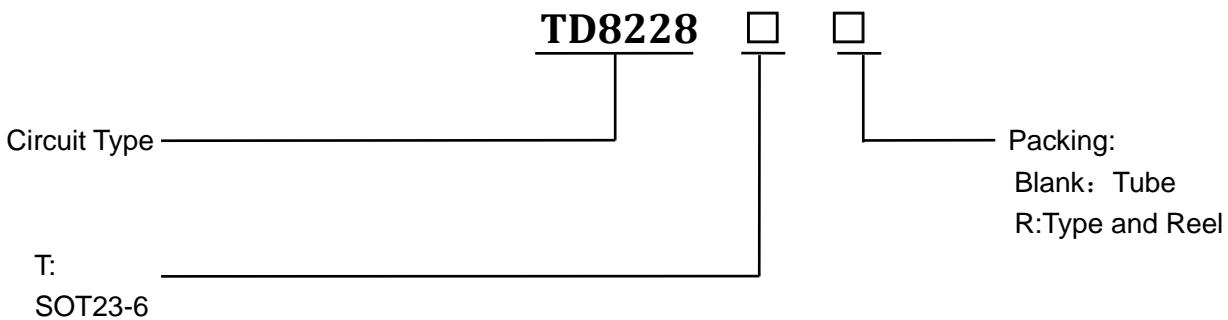

Figure 2 Pin Configuration of TD8228(Top View)

Pin Description

Pin Number	Pin Name	Description
1	LX	Inductor node. Connect an inductor between IN pin and LX pin.
2	GDN	GND
3	FB	Feedback pin. Connect a resistor R1 between V_{OUT} and FB, and a resistor R2 between FB and GND to program the output voltage: $V_{OUT}=0.6V*(R1/R2+1)$
4	EN	Enable control. High to turn on the part. Don't leave it floated.
5	IN	Power Input pin.
6	OC	Adjustable Over Current Protection $I_{OC}=120000/R$

Ordering Information



Function Block

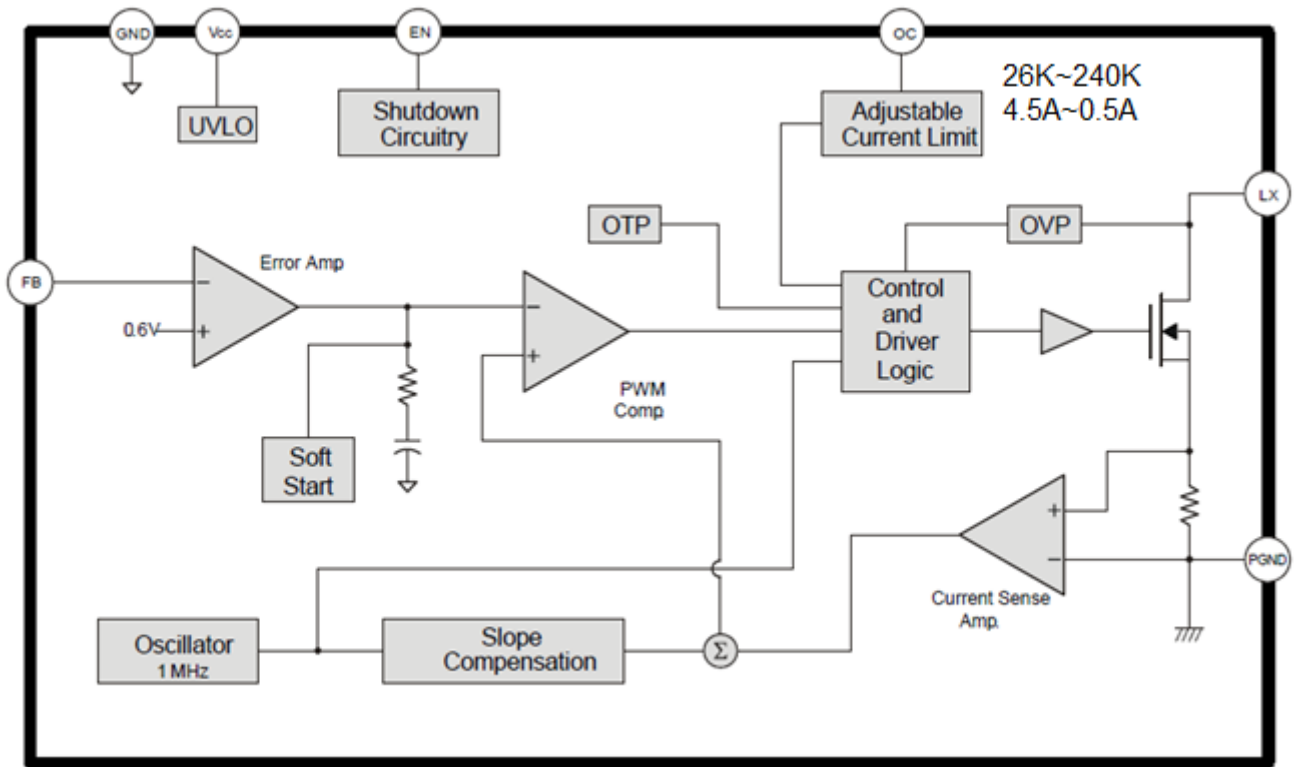

Figure 3 Function Block Diagram of TD8228

Absolute Maximum Ratings

EN, VDD, LX	7V
FB	3.6V
Power Dissipation, P_D @ $T_A = 25^\circ\text{C}$, SOT23-6	0.6W
Package Thermal Resistance (Note 2)	
SOT23-6, θ_{JA}	200°C/W
SOT23-6, θ_{JC}	130°C/W
Junction Temperature Range	125°C
Lead Temperature (Soldering, 10 sec.)	260°C
Storage Temperature Range	-65°C to 150°C

Recommended Operating Conditions

VDD pin	2V to 6V
FB	0V to 1V
Junction Temperature Range	-40°C to 125°C
Ambient Temperature Range	-40°C to 85°C

Electrical Characteristics

($V_{IN} = 3.3V$, $V_{OUT} = 5V$, $I_{OUT} = 100mA$, $T_A = 25^\circ C$ unless otherwise specified)

Parameters	Symbol	Test Condition	Min.	Typ.	Max.	Unit
Input Voltage Range	V_{IN}		2		6	V
Quiescent Current	I_Q	$V_{FB} = 0.66V$		200		μA
Low Side Main FET	Rds(on)			120		m Ω
Main FET Current	I_{LIM1}		3			A
Switching Frequency	Fsw		0.8	1	1.2	MHz
Feedback Reference	V_{REF}		0.588	0.6	0.612	V
IN UVLO Rising	$V_{IN,UVLO}$				1.9	V
OCP Current	Iocp			4.5		A
Adjustable OCP Current	Iocp	With External Resistor:26K~240K	0.5		4.5	A
Thermal Shutdown	T_{SD}			150		$^\circ C$

Typical Performance Characteristics

Efficiency vs Load Current

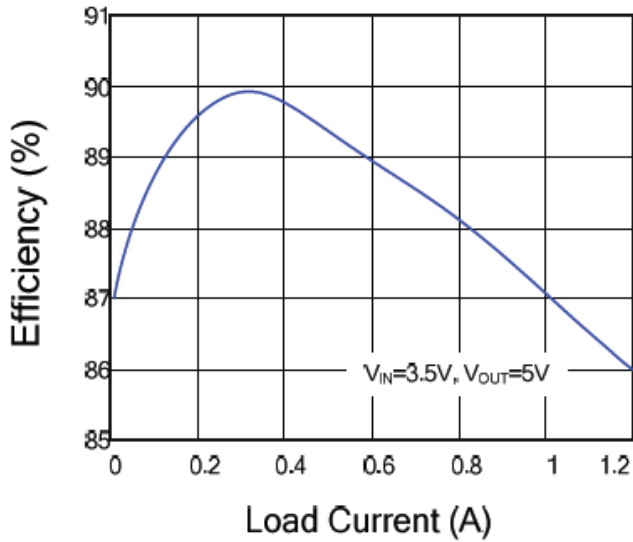

Load Transient

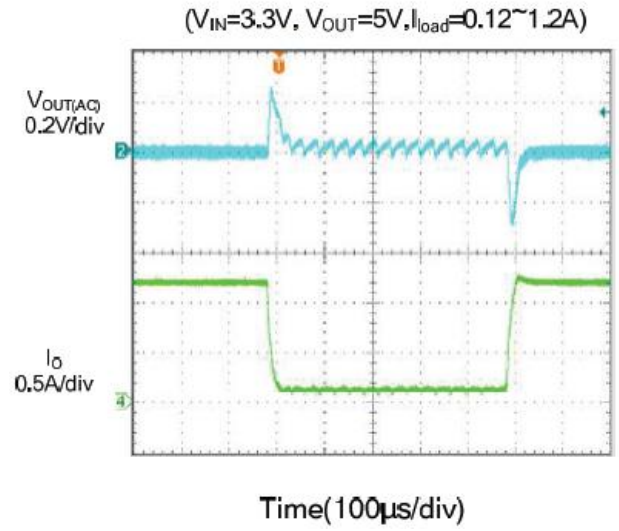

Startup from V_{IN}

($V_{IN}=3.3V, V_{OUT}=5V, I_{load}=1.2A$)

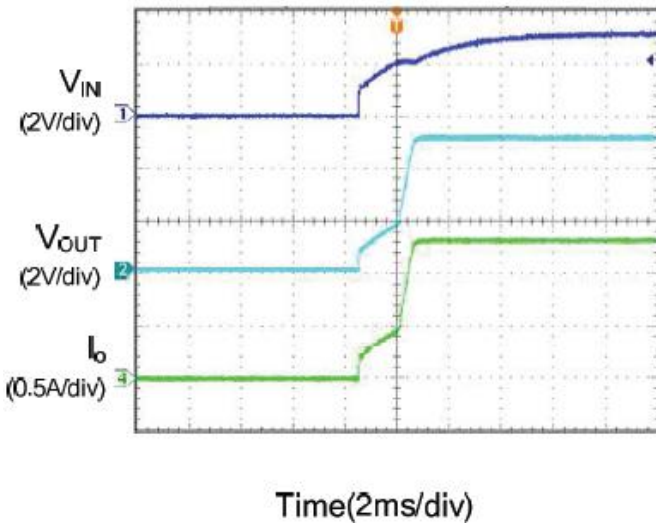

Shutdown from V_{IN}

($V_{IN}=3.3V, V_{OUT}=5V, I_{load}=1.2A$)

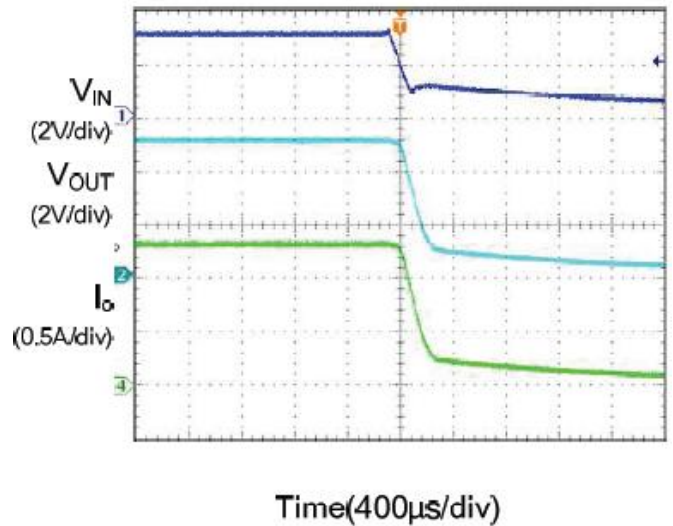

Startup from Enable

($V_{IN}=3.3V, V_{OUT}=5V, I_{load}=1.2A$)

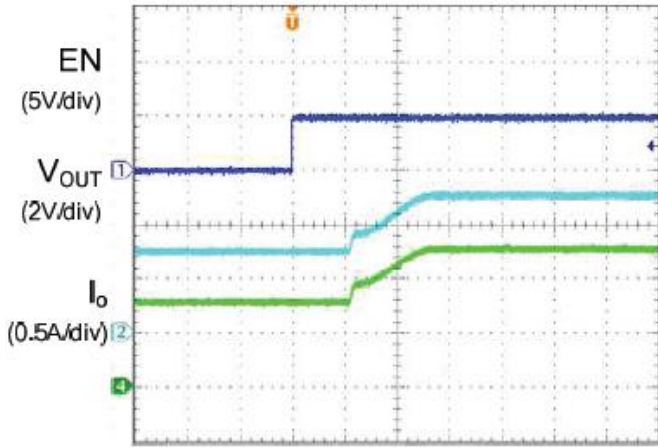

Time(2ms/div)

Shutdown from Enable

($V_{IN}=3.3V, V_{OUT}=5V, I_{load}=1.2A$)

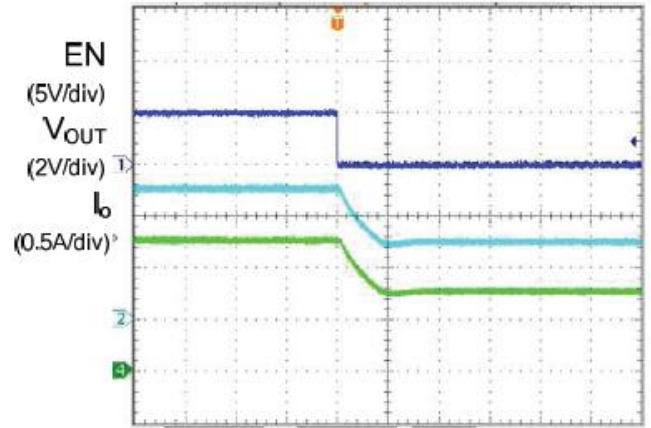

Time(40µs/div)

Output Ripple

($V_{IN}=3.3V, V_{OUT}=5V, I_O=1.2A$)

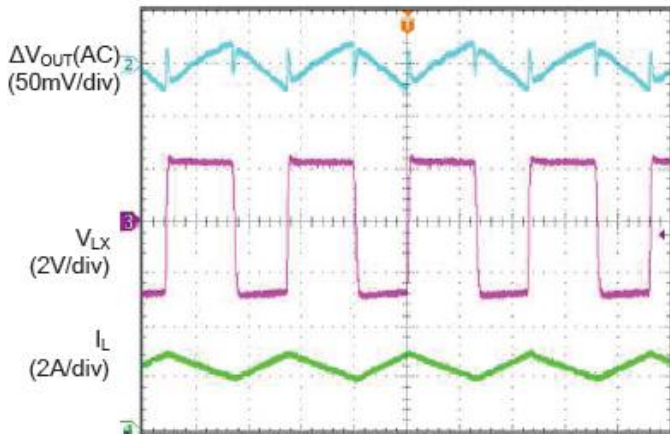

Time(400ns/div)

Output Ripple

($V_{IN}=3.3V, V_{OUT}=5V, I_O=0.6A$)

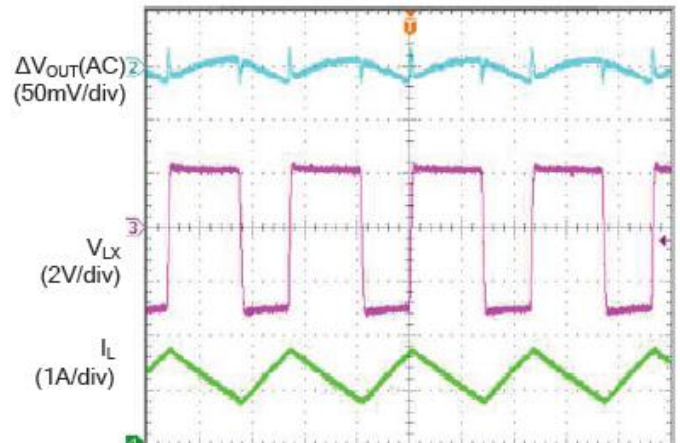

Time(400ns/div)

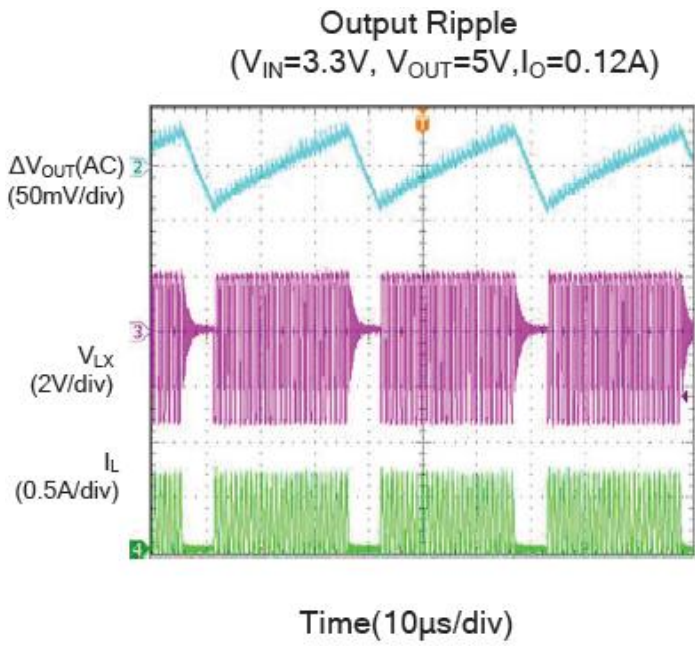

Typical Application Circuit

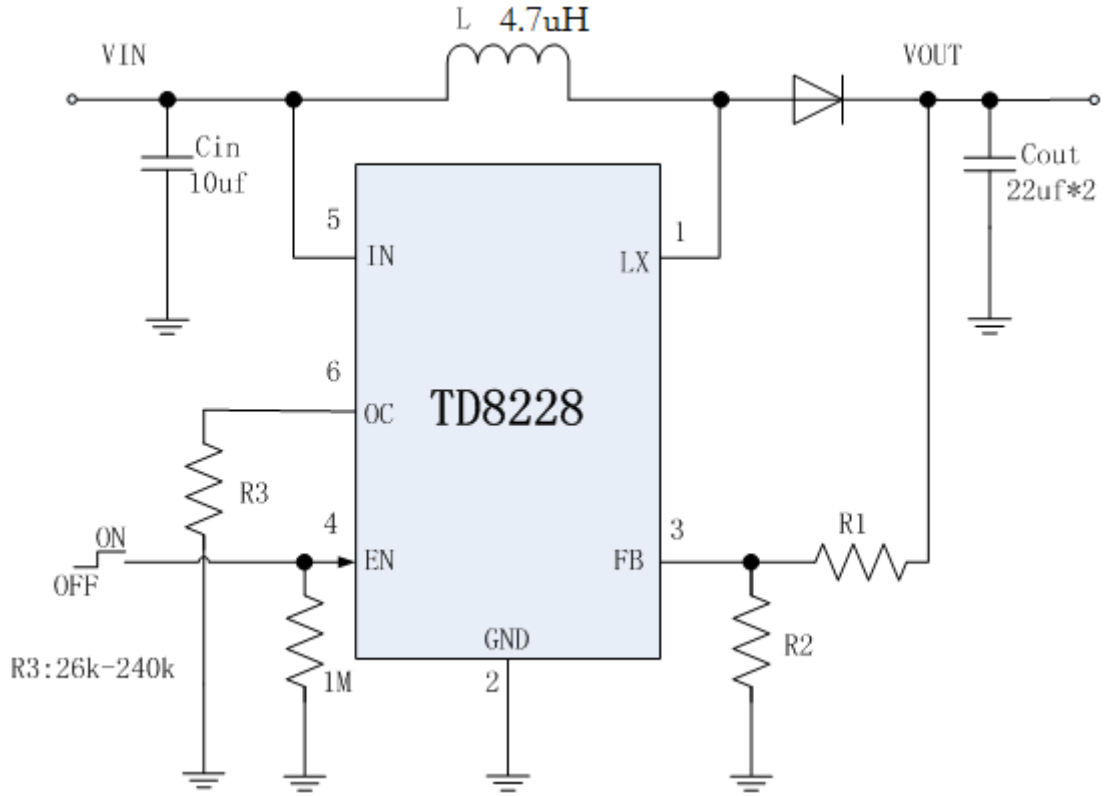

Function Description

Because of the high integration in the TD8228 IC, the application circuit based on this regulator IC is rather simple. Only input capacitor C_{IN} , output capacitor C_{OUT} , inductor L and feedback resistors (R_1 and R_2) need to be selected for the targeted applications specifications.

Feedback resistor dividers R_1 and R_2 :

Choose R_1 and R_2 to program the proper output voltage. To minimize the power consumption under light loads, it is desirable to choose large resistance values for both R_1 and R_2 . A value of between 10k and 1M is recommended for both resistors. If $R_1=200k$ is chosen, then R_2 can be calculated to be:

$$R_2 = (R_1 \times 0.6V) / (V_{OUT} - 0.6V)$$

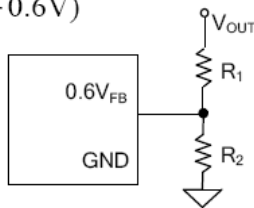

Output capacitor C_{OUT} :

The output capacitor is selected to handle the output ripple noise requirements. Both steady state ripple and transient requirements must be taken into consideration when selecting this capacitor. For the best performance, it is recommended to use X5R or better grade ceramic capacitor with 25V rating and more than two pcs 10uF capacitor.

Input capacitor C_{IN} :

The ripple current through input capacitor is calculated as:

$$I_{CIN_RMS} = \frac{V_{IN} \cdot (V_{OUT} - V_{IN})}{2\sqrt{3} \cdot L \cdot F_{SW} \cdot V_{OUT}} \text{ (A)}$$

To minimize the potential noise problem, place a typical X5R or better grade ceramic capacitor really close to the VDD and GND pins. Care should be taken to minimize the loop area formed by C_{IN} , and VDD/GND pins. In this case a 22uF low ESR ceramic capacitor is recommended.

Boost inductor L :

There are several considerations in choosing this inductor.

1) Choose the inductance to provide the desired ripple current. It is suggested to choose the ripple current to be about 40% of the maximum average input current. The inductance is calculated as:

$$L = \left(\frac{V_{IN}}{V_{OUT}} \right)^2 \frac{(V_{OUT} - V_{IN})}{F_{SW} \times I_{OUT_MAX} \times 40\%}$$

where F_{SW} is the switching frequency and I_{OUT_MAX} is the maximum load current.

The TD8228 regulator IC is quite tolerant of different ripple current amplitude. Consequently, the final choice of inductance can be slightly off the calculation value without significantly impacting the performance.

2) The saturation current rating of the inductor must be selected to be greater than the peak inductor current under full load conditions.

$$I_{STA_MIN} > \left(\frac{V_{OUT}}{V_{IN}} \right) \times I_{OUT_MAX} + \frac{V_{IN}(V_{OUT} - V_{IN})}{2 \times F_{SW} \times L \times V_{OUT}}$$

3) The DCR of the inductor and the core loss at the switching frequency must be low enough to achieve the desired efficiency requirement. It is desirable to choose an inductor with $DCR < 50\text{mohm}$ to achieve a good overall efficiency.

Enable Operation

Pulling the EN pin low (<0.4V) will shut down the device. During the shut down mode, the TD8228 shut down current drops to lower than 1uA, Driving the EN pin high (>2.0V) will turn on the IC again.

Diode Selection

Schottky diode is a good choice for high efficiency operation because of its low forward voltage drop and fast reverse recovery. The current rating of the diode must meet following:

$$I_D(RMS) \approx \sqrt{I_{OUT} \times I_{PEAK}}$$

The schottky diode reverse breakdown voltage should be larger than the output voltage

Current Limit Program:

A resistor between OC and GND pin programs peak switch current. The resistor value should be between 26K and 240K. The current limit will be set from 0.5A to 4.5A. Keep traces at this pin as short as possible. Do not put capacitance at this pin. To set the over current trip point according to the following equation:

$$I_{OCP} = 120000/R$$

Layout Design:

The layout design of TD8228 regulator is relatively simple. For the best efficiency and minimum noise problems, we should place the following components close to the IC: C_{IN}, L, R₁ and R₂.

- 1) It is desirable to maximize the PCB copper area connecting to GND pin to achieve the best thermal and noise performance. If the board space allowed, a ground plane is highly desirable.
- 2) C_{IN} must be close to Pins IN and GND. The loop area formed by C_{IN} and GND must be minimized.
- 3) The PCB copper area associated with LX pin must be minimized to avoid the potential noise problem.
- 4) The components R₁ and R₂, and the trace connecting to the FB pin must NOT be adjacent to the LX net on the PCB layout to avoid the noise problem.
- 5) If the system chip interfacing with the EN pin has a high impedance state at shutdown mode and the IN pin is connected directly to a power source such as a Li-Ion battery, it is desirable to add a pull down 1Mohm resistor between the EN and GND pins to prevent the noise from falsely turning on the regulator at shutdown mode.

Package Information

SOT23-6 Package Outline Dimensions

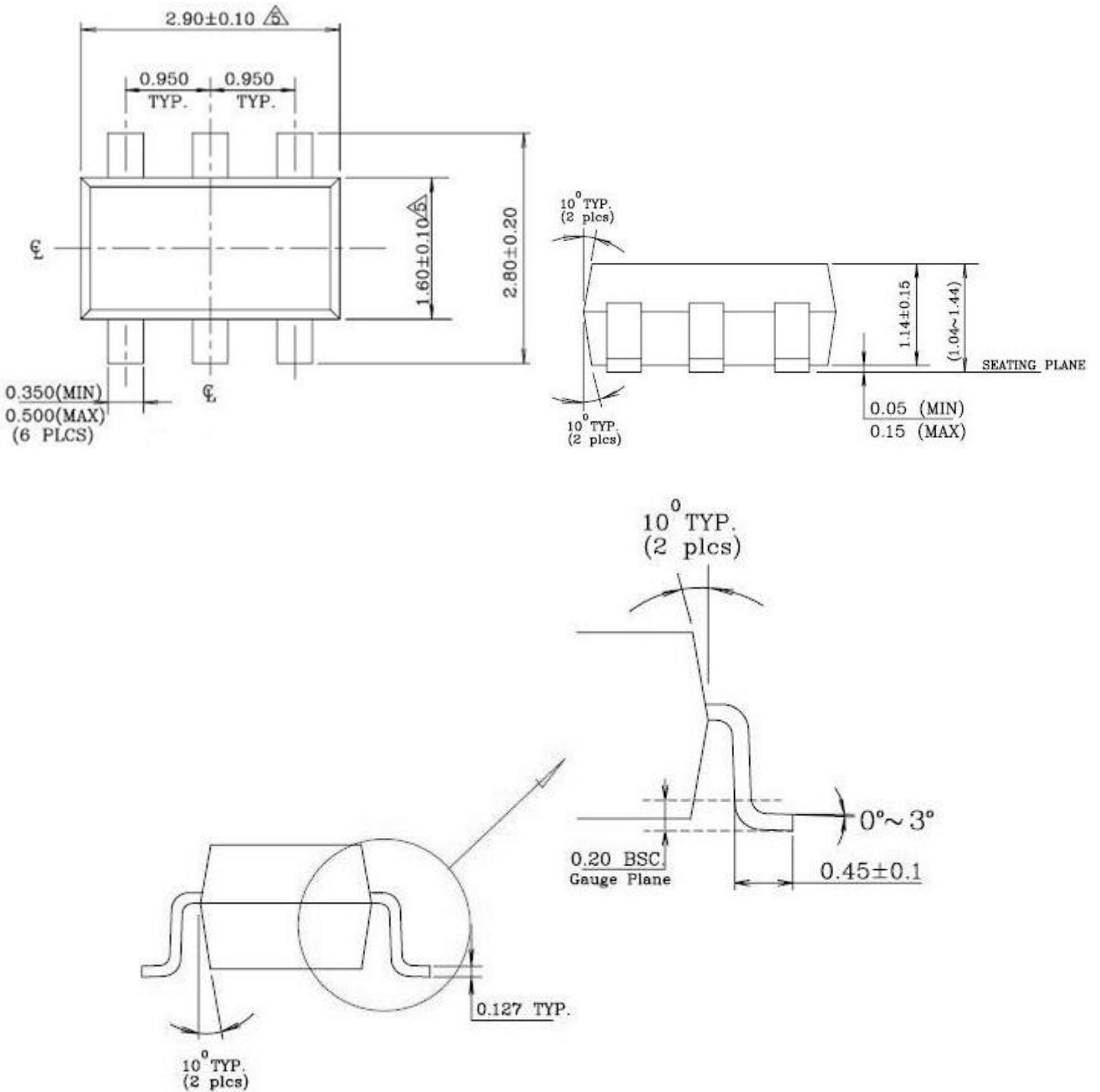

Design Notes