

VOLTAGE RANGE: 5 - 16KV
CURRENT: 350mA

Features

- Low cost
- Low leakage
- Isolated case
- Surge overload rating - 50 amperes peak
- Low forward voltage drop

Mechanical Data

- Case: Molded plastic
- Epoxy: UL 94V-0 rate flame retardant
- Lead: MIL-STD-202E, Method 208 guaranteed
- Polarity: Color band denotes cathode end
- Mounting position: Any

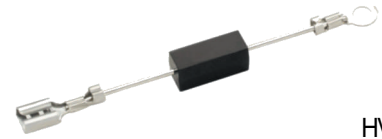

HVM

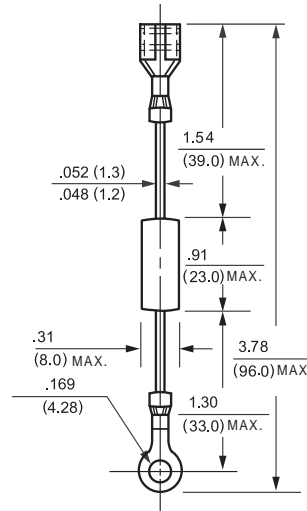

Dimensions in inches and (millimeters)

Maximum Ratings and Electrical Characteristics $T_A = 25^\circ\text{C}$ unless otherwise specified

Single phase, half wave, 60Hz, resistive or inductive load. For capacitive load, derate current by 20%.

Characteristic	Symbol	HVM5	HVM8	HVM10	HVM12	HVM14	HVM15	HVM16	Unit
Maximum Recurrent Peak Reverse Voltage	V_{RRM}	5	8	10	12	14	15	16	K Volts
Maximum RMS Voltage	V_{RMS}	3.5	5.6	7.0	8.4	9.8	10.5	11.2	K Volts
Maximum DC Blocking Voltage	V_{DC}	5	8	10	12	14	15	16	K Volts
Maximum Average Forward Rectified Current at $T_A = 50^\circ\text{C}$	I_O	350							mAmps
Peak Forward Surge Current 8.3 ms single half sine-wave superimposed on rated load (JEDEC Method)	I_{FSM}	50							Amps
Maximum Instantaneous Forward Voltage at 0.35A DC	V_F	8.0	13.5				14.0		Volts
Maximum DC Reverse Current at Rated DC Blocking Voltage $T_A = 25^\circ\text{C}$	I_R	5.0							μAmps
Operating and Storage Temperature Range	T_J, T_{STG}	-20 to + 135							$^\circ\text{C}$

NOTES:1. Enough heat sink must be considered in application.
 2. Suffix "-Tox" (e.g.-T01,-T02,.....) for Terminal type.