

VOLTAGE RANGE: 50 - 1000V
CURRENT: 3.0 A

Features

- Diffused Junction
- Ultra-Fast Switching for High Efficiency
- High Current Capability and Low Forward Voltage Drop
- Low Reverse Leakage Current
- Plastic Material: UL Flammability Classification Rating 94V-0

Mechanical Data

- Case: DO-201AD, Molded Plastic
- Terminals: Plated Leads Solderable per MIL-STD-202, Method 208
- Polarity: Cathode Band
- Weight: 1.2 grams (approx.)
- Mounting Position: Any
- Marking: Type Number

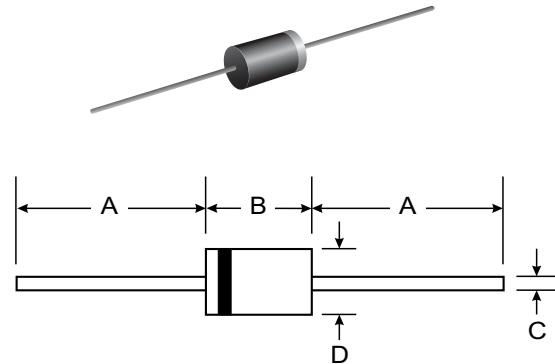

| DO-201AD | | |
|----------------------|-------|------|
| Dim | Min | Max |
| A | 25.40 | — |
| B | 7.20 | 9.50 |
| C | 1.20 | 1.30 |
| D | 4.80 | 5.30 |
| All Dimensions in mm | | |

Maximum Ratings and Electrical Characteristics @ T_A = 25°C unless otherwise specified

Single phase, half wave, 60Hz, resistive or inductive load. For capacitive load, derate current by 20%.

| Characteristic | Symbol | UF 3001 | UF 3002 | UF 3003 | UF 3004 | UF 3005 | UF 3006 | UF 3007 | Unit |
|---|--|-------------|---------|---------|---------|---------|---------|---------|------|
| Peak Repetitive Reverse Voltage Working Peak Reverse Voltage DC Blocking Voltage | V _{RRM} V _{RWM} V _R | 50 | 100 | 200 | 400 | 600 | 800 | 1000 | V |
| RMS Reverse Voltage | V _{R(RMS)} | 35 | 70 | 140 | 280 | 420 | 560 | 700 | V |
| Average Rectified Output Current (Note 1) @ T _A = 55°C | I _O | 3.0 | | | | | | | A |
| Non-Repetitive Peak Forward Surge Current 8.3ms Single half sine-wave Superimposed on Rated Load (JEDEC Method) | I _{FSM} | 150 | | | | | | | A |
| Forward Voltage @ I _F = 3.0A | V _{FM} | 1.0 | | 1.3 | 1.7 | | | V | |
| Peak Reverse Current @ T _A = 25°C at Rated DC Blocking Voltage @ T _A = 100°C | I _{RM} | 5.0 100 | | | | | | | μA |
| Reverse Recovery Time (Note 3) | t _{rr} | 50 | | | | 75 | | | ns |
| Typical Junction Capacitance (Note 2) | C _j | 75 | | | | 50 | | | pF |
| Typical Thermal Resistance Junction to Ambient | R _{θJA} | 35 | | | | | | | K/W |
| Operating and Storage Temperature Range | T _j , T _{STG} | -65 to +150 | | | | | | | °C |

- Notes:
1. Valid provided that leads are maintained at ambient temperature at a distance of 9.5mm from the case.
 2. Measured at 1.0MHz and Applied Reverse Voltage of 4.0V DC.
 3. Measured with I_F = 0.5A, I_R = 1.0A, I_{rr} = 0.25A. See Figure 5.

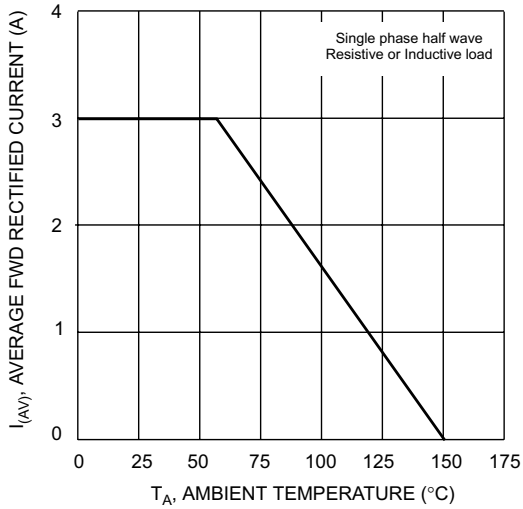

Fig. 1 Forward Current Derating Curve

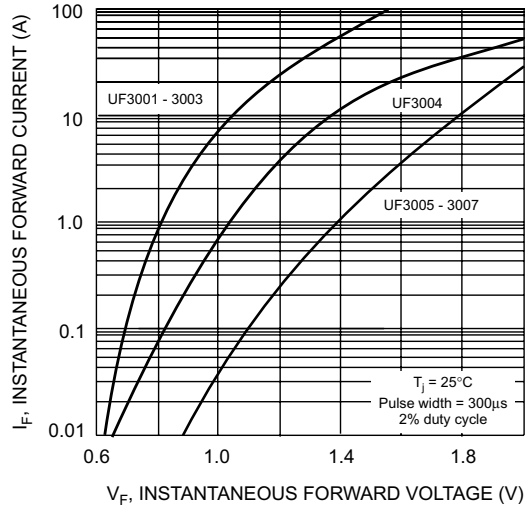

Fig. 2 Typical Forward Characteristics

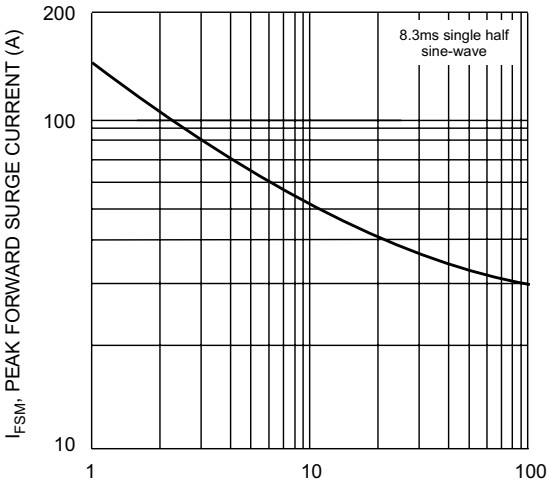

Fig. 3 Peak Forward Surge Current

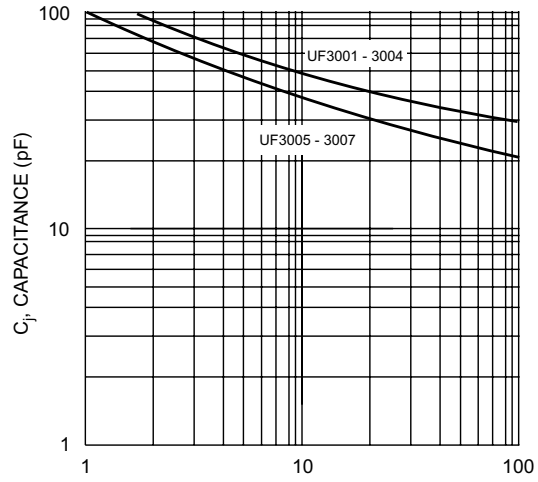
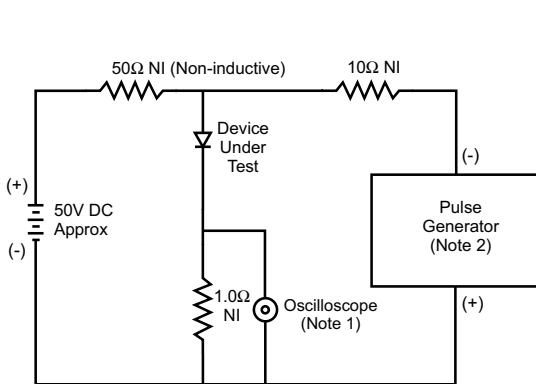
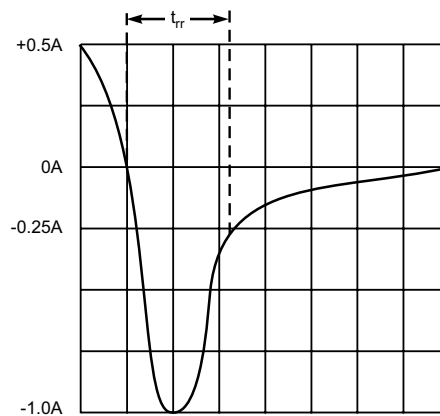

Fig. 4 Typical Junction Capacitance



- Notes:
1. Rise Time = 7.0ns max. Input Impedance = 1.0MΩ, 22pF.
 2. Rise Time = 10ns max. Input Impedance = 50Ω.



Set time base for 50/100 ns/cm

Fig. 5 Reverse Recovery Time Characteristic and Test Circuit