

**VOLTAGE RANGE: 40 - 200V**

**CURRENT: 20A**

### Features

- High efficiency operation
- Low power loss
- Low stored charge majority carrier conduction
- High forward surge capability
- Lead free in compliance with EU RoHS 2011/65/EU directive
- Green molding compound as per IEC61249 Std (Halogen Free)

### Mechanical Data

- Circuit figure: Common cathode
- Leads: Solderable per mil-std-202, Method 208
- Polarity: as marked
- Mounting torque: 5 in-lbs maximum
- Terminals: Puretin plated
- Weight: TO-220AB 1.85 grams

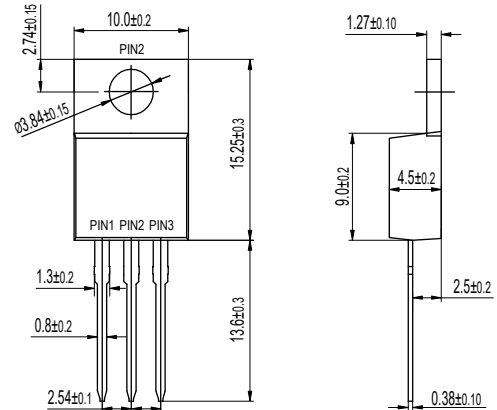
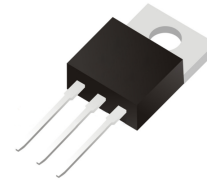

TO-220AB

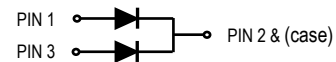

### Maximum Ratings and Electrical Characteristics T<sub>A</sub> = 25°C unless otherwise specified

RATINGS	SYMBOL	MBR 20H40CT	MBR 20H45CT	MBR 20H60CT	MBR 20H100CT	MBR 20H150CT	MBR 20H200CT	UNIT
Maximum repetitive reverse voltage	VRRM	40	45	60	100	150	200	V
Maximum RMS voltage	VRMS	28	32	42	70	105	140	V
Maximum DC blocking voltage	VDC	40	45	60	100	150	200	V
Maximum average forward current per device per diode	I <sub>AV</sub>	20				10		A
Peak forward surge current, 8.3ms single half sine-wave superimposed on rated load	I <sub>FSM</sub>	220						A
Typical thermal resistance (Note 1)	R <sub>θ-JC</sub>	2.0						°C/W
Operating junction temperature range	T <sub>J</sub>	-55 to +150				-55 to +175		°C
Storage temperature range	T <sub>STG</sub>	-55 to +175						°C
Maximum forward voltage per leg at I <sub>F</sub> =10A	V <sub>F</sub>	0.65	0.75	0.85	0.92		V	
Maximum average reverse current at rated DC blocking voltage <small>T<sub>J</sub>=25°C T<sub>J</sub>=125°C</small>	I <sub>R</sub>	0.10 15		0.01 5			mA	

FIG. 1 - TYPICAL FORWARD CURRENT DERATING CURVE

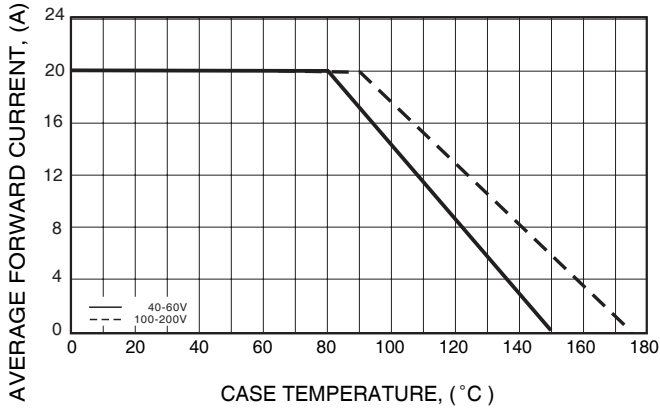

FIG. 2 - MAXIMUM NON-REPETITIVE FORWARD SURGE CURRENT

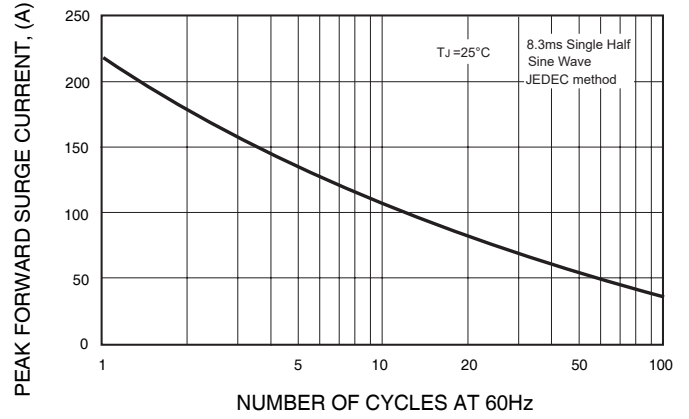

FIG. 3 - TYPICAL REVERSE CHARACTERISTICS

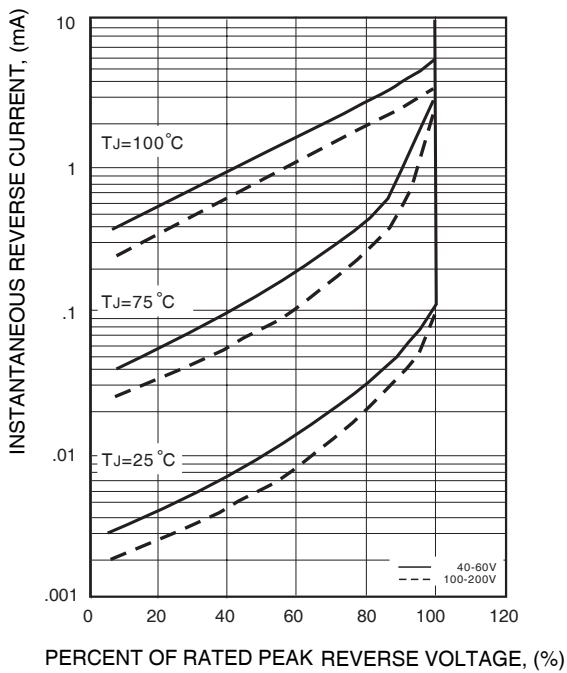

FIG. 4 - TYPICAL INSTANTANEOUS FORWARD CHARACTERISTICS

