

VOLTAGE RANGE: 40 - 200V

CURRENT: 8.0 A

Features

- High efficiency operation
- Low power loss
- Low stored charge majority carrier conduction
- High forward surge capability
- Lead free in compliance with EU RoHS 2011/65/EU directive
- Green molding compound as per IEC61249 Std..(Halogen Free)

Mechanical Data

- Circuit figure: Common cathode
- Leads: Solderable per mil-std-202, Method 208
- Polarity: as marked
- Mounting torque: 5 in-lbs maximum
- Terminals: Puretin plated
- Weight: TO-220AB 1.85 grams

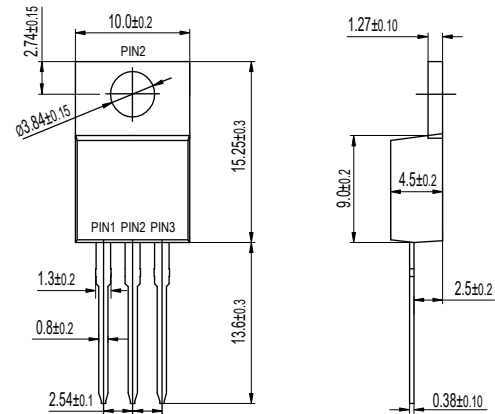
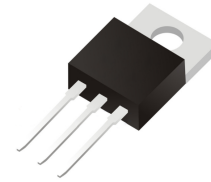

TO-220AB

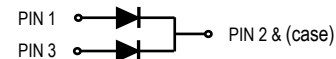

Maximum Ratings and Electrical Characteristics $T_A = 25^\circ\text{C}$ unless otherwise specified

RATINGS	SYMBOL	MBR840CT	MBR845CT	MBR860CT	MBR8100CT	MBR8150CT	MBR8200CT	UNIT
Maximum repetitive reverse voltage	VRRM	40	45	60	100	150	200	V
Maximum RMS voltage	VRMS	28	32	42	70	105	140	V
Maximum DC blocking voltage	VDC	40	45	60	100	150	200	V
Maximum average forward current	I _{AV}	8						A
Peak forward surge current, 8.3ms single half sine-wave superimposed on rated load	I _{FSM}	100						A
Typical thermal resistance	R _{θ-JC}	2.0						°C/W
Operating junction temperature range	T _J	-55 to +150				-55 to +175		°C
Storage temperature range	T _{STG}	-55 to +175						°C
Maximum forward voltage per leg at I _F =8A	V _F	0.65	0.75	0.85	0.92		V	
Maximum average reverse current at rated DC blocking voltage $T_J=25^\circ\text{C}$ $T_J=125^\circ\text{C}$	I _R	0.10 15			0.01 5		mA	

Notes: 1. Thermal resistance from junction to case.

FIG. 1 - TYPICAL FORWARD CURRENT DERATING CURVE

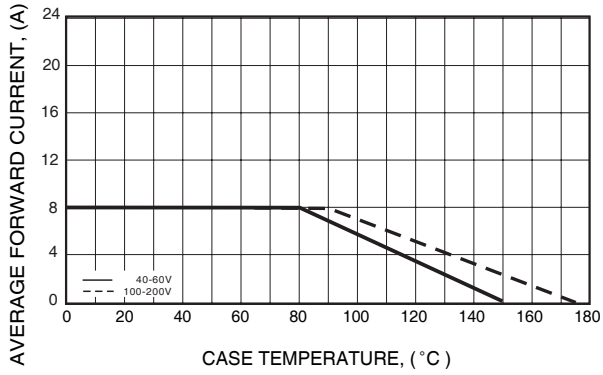

FIG. 2 - MAXIMUM NON-REPETITIVE FORWARD SURGE CURRENT

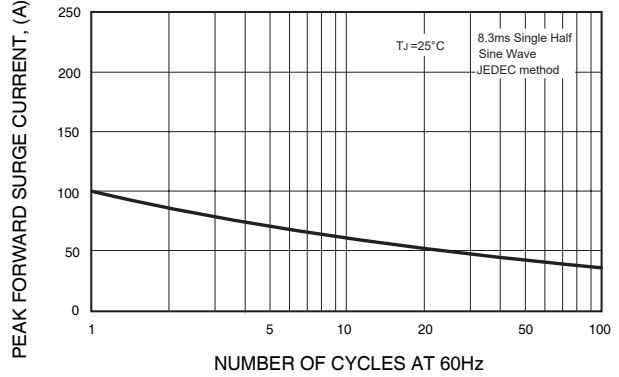

FIG. 3 - TYPICAL REVERSE CHARACTERISTICS

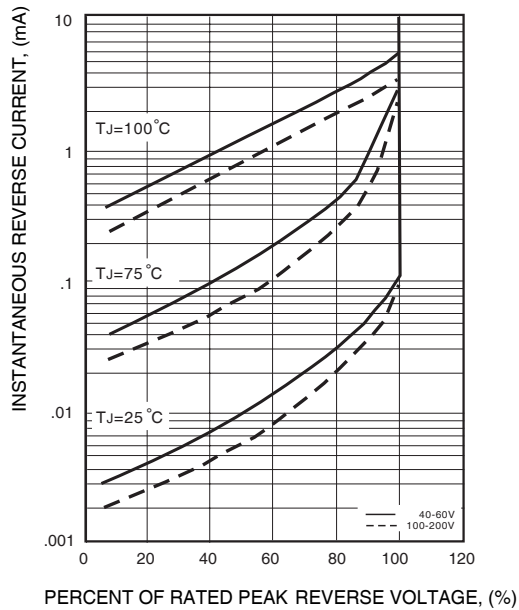

FIG. 4 - TYPICAL INSTANTANEOUS FORWARD CHARACTERISTICS

