

Description

The SMBJ3.3A is designed specifically to protect sensitive electronic equipment from voltage transients induced by lightning and other transient voltage events.

Features

- I Very fast response time
- I Halogen free and RoHS compliant
- I Low incremental surge resistance
- I Optimized for LAN protection applications
- I Matte tin lead-free Plated
- I For surface mounted applications to optimize board space
- I High temperature soldering:260°C/10 seconds at terminals

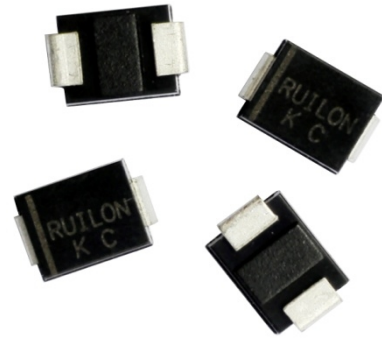

Electrical symbol

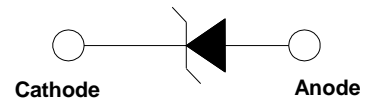

Part Number Code

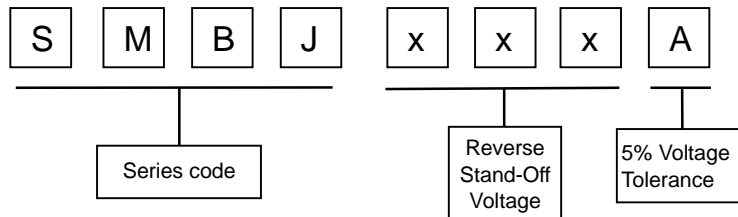

Mechanical Characteristics

Rating	Symbol	Value	Units
Peak Pulse Power Dissipation at $T_A=25^\circ\text{C}$ by 10/1000 μs Waveform (Fig.2)(Note 1), (Note 2)	P_{PP}	600	W
Power Dissipation on Infinite Heat Sink at $T_L=75^\circ\text{C}$ (Fig.6)	P_D	5.0	W
Peak Forward Surge Current, 8.3ms Single Half Sine Wave (Note 3)	I_{FSM}	100	A
Operating Temperature Range	T_J	-55 to 150	$^\circ\text{C}$
Storage Temperature Range	T_{STG}	-55 to 150	$^\circ\text{C}$

Notes:

1. Non-repetitive current pulse, per Fig.4 and derated above $T_A=25^\circ\text{C}$ per Fig. 3.
2. Mounted on 5.0x5.0mm copper pad to each terminal.
3. Measured on 8.3ms single half sine wave or equivalent square wave for unidirectional device only, duty cycle=4 per minute maximum.



Electrical Characteristics

Type Number	Marking	Reverse Stand-Off Voltage	Breakdown Voltage		Test Current	Max. Clamping Voltage	Max. Peak Pulse Current	Reverse Leakage
		V_{RWM}	$V_{BR} @ I_T$		I_T	$V_C @ I_{PP}$	I_{PP}	$I_R @ V_{RWM}$
			Min	Max				
UNI	UNI	V	V	V	mA	V	A	μ A
SMBJ3.3A	KC	3.3	4	6	1	7.3	50	200

I-V Curve Characteristics

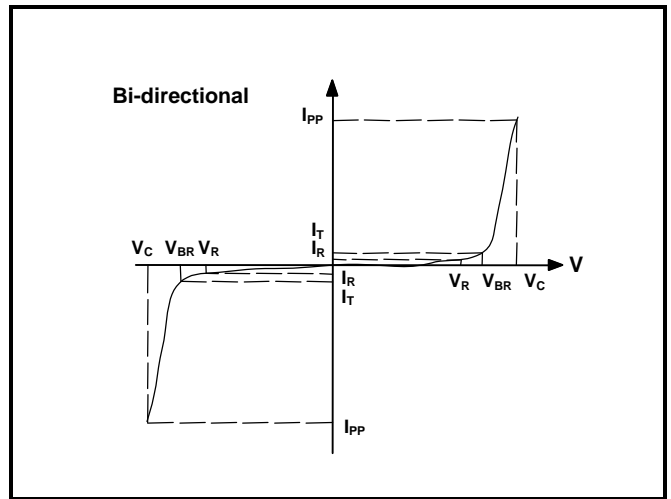
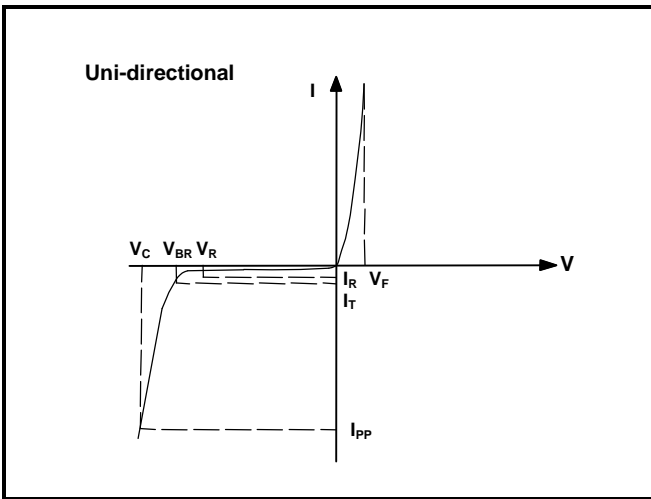

P_{PPM} Peak Pulse Power Dissipation -- Max power dissipation
 V_R Stand-off Voltage -- Maximum voltage that can be applied to the TVS without operation
 V_{BR} Breakdown Voltage -- Maximum voltage that flows through the TVS at a specified test current (I_T)
 V_C Clamping Voltage -- Peak voltage measured across the TVS at a specified I_{ppm} (peak impulse current)
 I_R Reverse Leakage Current -- Current measured at V_R
 V_F Forward Voltage Drop for Uni-directional

Ratings and Characteristic Curves ($T_A=25^\circ\text{C}$ unless otherwise noted)

Figure 1 - TVS Transients Clamping Waveform

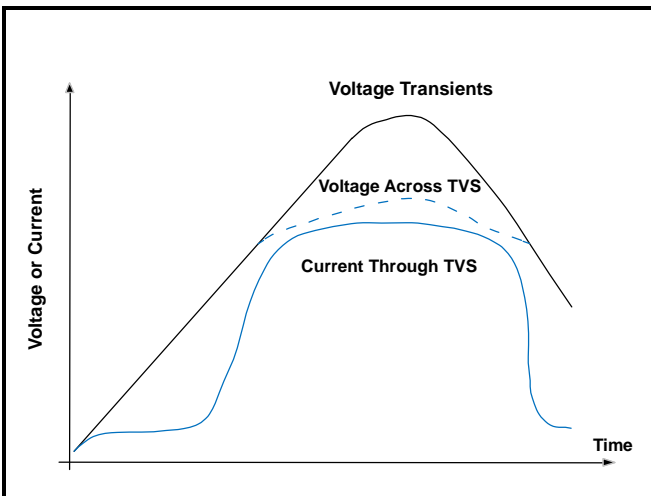
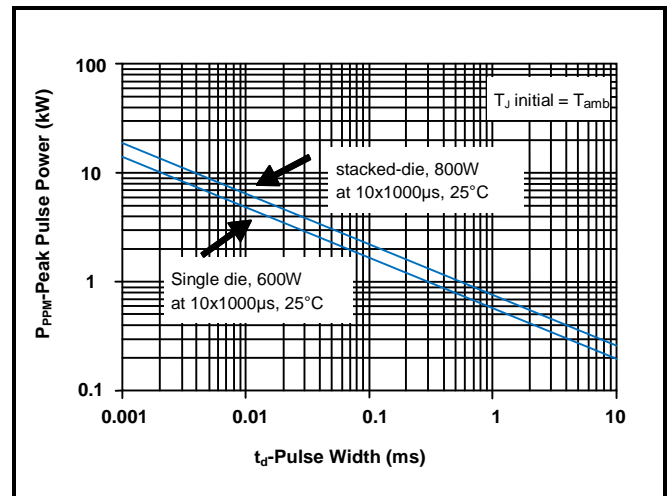

Figure 2 - Peak Pulse Power Rating Curve



Ratings and Characteristic Curves ($T_A=25^\circ\text{C}$ unless otherwise noted)

Figure 3 - Pulse Derating Curve

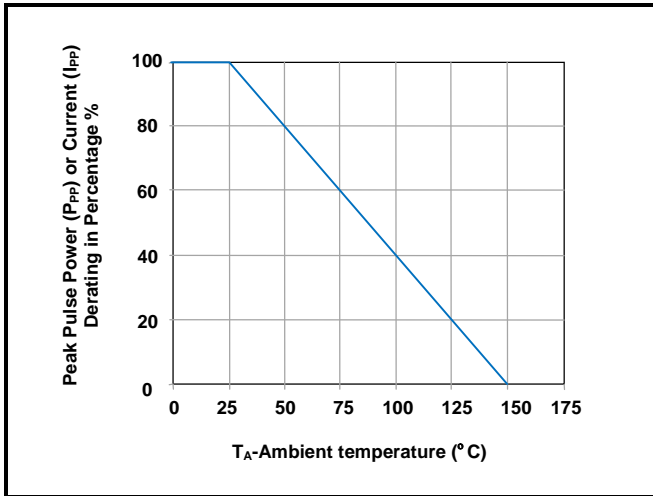

Figure 4 - Pulse Waveform

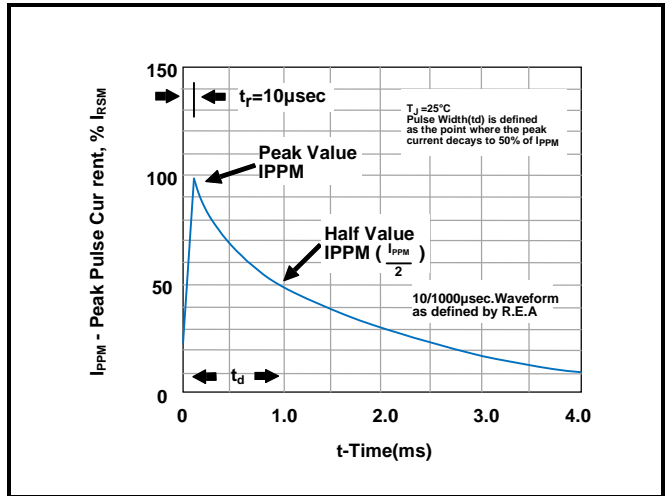

Figure 5 - Typical Junction Capacitance

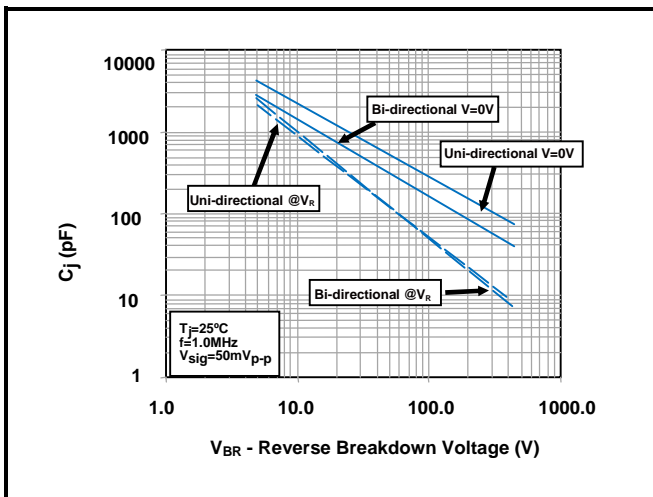

Figure 6 - Steady State Power Derating Curve

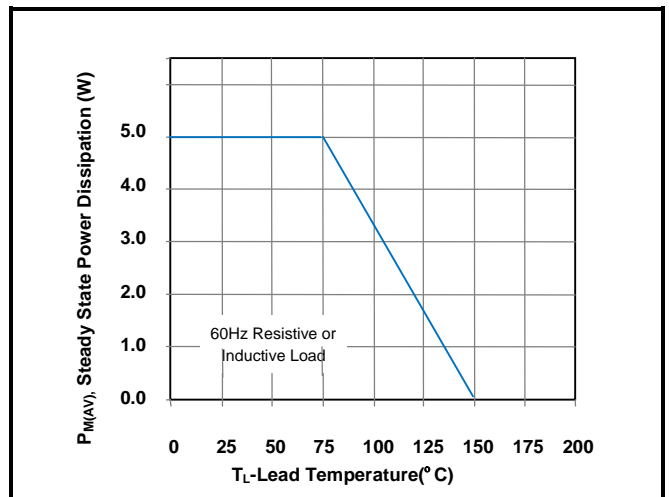
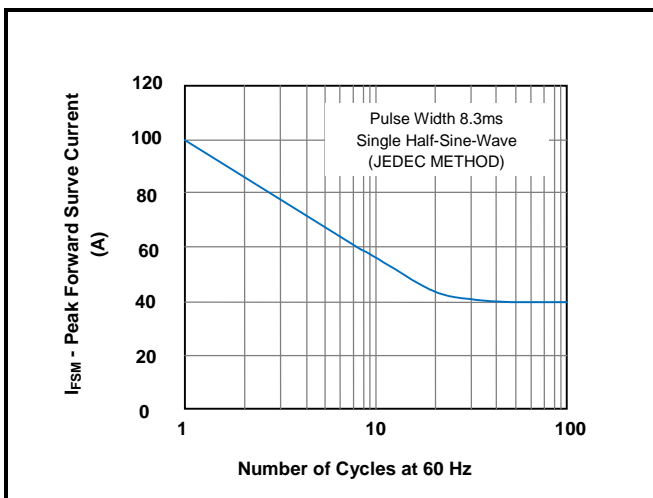
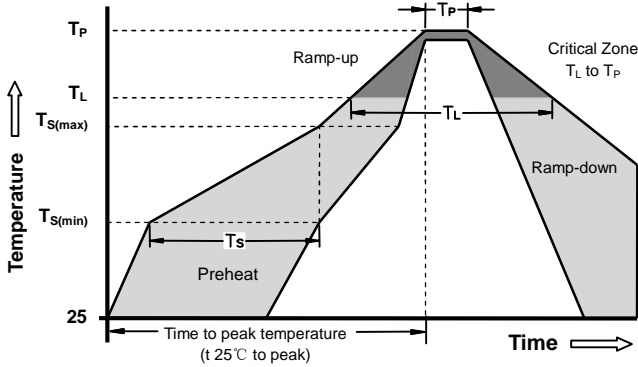

Figure 7 - Maximum Non-Repetitive Surge Current



Soldering Parameters - Reflow Soldering (Surface Mount Devices)



Reflow Condition		Pb - Free assembly
Pre Heat	-Temperature Min ($T_{s(min)}$)	150°C
	-Temperature Max ($T_{s(max)}$)	200°C
	- Time (min to max) (t_s)	60 -180 Seconds
Average ramp up rate (Liquids Temp T_L) to peak		3°C/second max
$T_{s(max)}$ to T_L - Ramp-up Rate		3°C/second max
Reflow	- Temperature (T_L) (Liquids)	217°C
	- Time (min to max) (t_s)	60 -150 Seconds
Peak Temperature (T_P)		260 +0/-5°C
Time within 5°C of actual peak Temperature (t_p)		20 - 40 Seconds
Ramp-down Rate		6°C/second max
Time 25°C to peak Temperature (T_P)		8 minutes Max
Do not exceed		260°C

Part Marking System

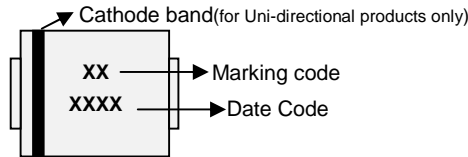

Dimensions

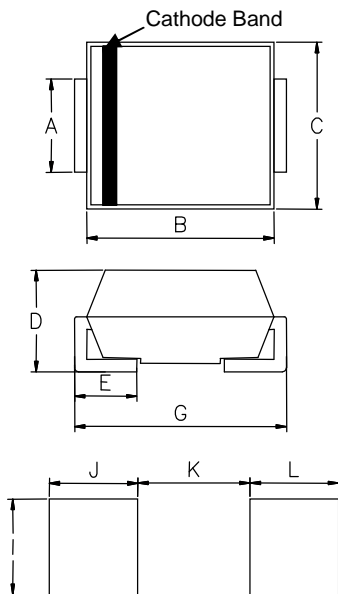

DIM	Millimeters		Inches	
	Min	Max	Min	Max
A	1.80	2.20	0.071	0.086
B	4.05	4.65	0.160	0.183
C	3.30	3.94	0.130	0.155
D	2.05	2.45	0.081	0.096
E	0.76	1.52	0.030	0.060
G	5.11	5.59	0.201	0.220
I	2.26	-	0.089	-
J	2.16	-	0.085	-
K	-	2.74	-	0.107
L	2.16	-	0.085	-



Taping and Reel Specifications

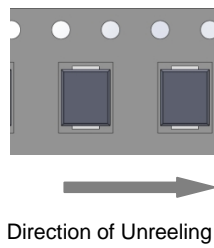
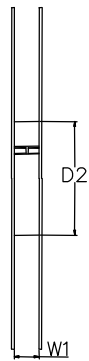
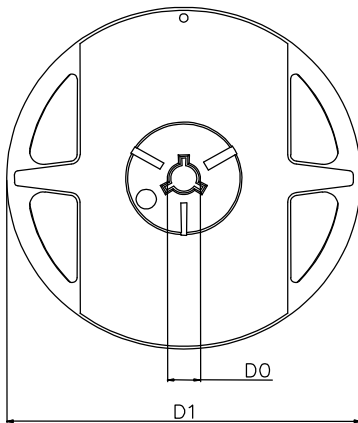
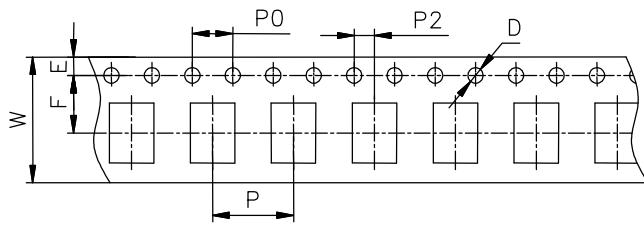

Symbol	Millimeters	Inches
W	12±0.3	0.472±0.012
P	8±0.1	0.315±0.004
F	5.5±0.1	0.217±0.004
E	1.75±0.1	0.069±0.004
D	1.5+0.1/-0.0	0.059+0.004/-0.0
P0	4±0.1	0.157±0.004
P2	2±0.1	0.079±0.004
D0	16.7±0.15	0.657±0.006
D1	178±2	7.007±0.079
D2	59.6+1/-2	2.346+0.039/-0.079
W1	12.64±0.4	0.498±0.016

Part Number	Component package	Quantity	Packaging option	Packaging specification
SMBJ3.3A	DO-214AA(SMB)	500	Tape&Reel-12mm/7"tape	EIA STD RS-481

