

Description

The principle of gas discharge is used not only for overvoltage protection but also in switching applications. Unlike surge arresters, switching spark gaps are active components that work reliably even after igniting hundreds of thousands of times.

RUILON 2RK-5 series Switching Spark Gaps(SSG) can be used in all applications where high voltage pulses are generated, for example to ignite modern high-pressure gas discharge lamps such as xenon lamps in automotive headlights. Ignition performance is determined to a large degree by the properties of the switching component. An extremely fast switch is called for, which operates virtually without loss and with high insulation resistance in the non-conducting state. It should also be as compact as possible, rugged, highly reliable, and capable of operating over a wide temperature range.

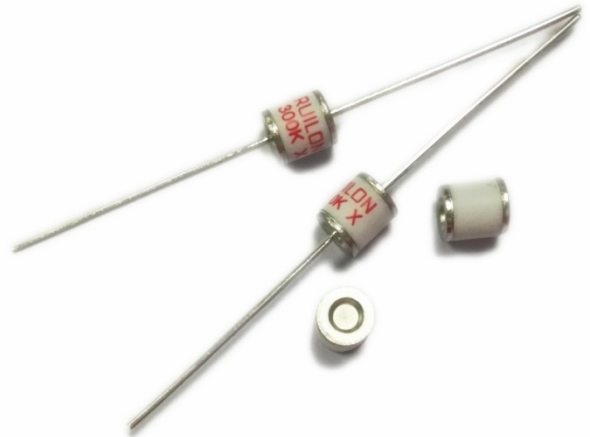

Features

- I Extremely long life time
- I Stable performance over life
- I Insensitive performance against variations in temperature
- I Low switching losses
- I Very short breakdown time
- I High reliability by robust design
- I Lead-free and RoHS compliant
- I Non-Radioactive

Applications

- I Igniters for architectural and automotive Xenon discharge lamps
- I Electronic igniters for gas heating and gas domestic appliances, e.g., cookers
- I Ignition of ultra-high pressure gas discharge lamps for data and video projectors

Part Number Code

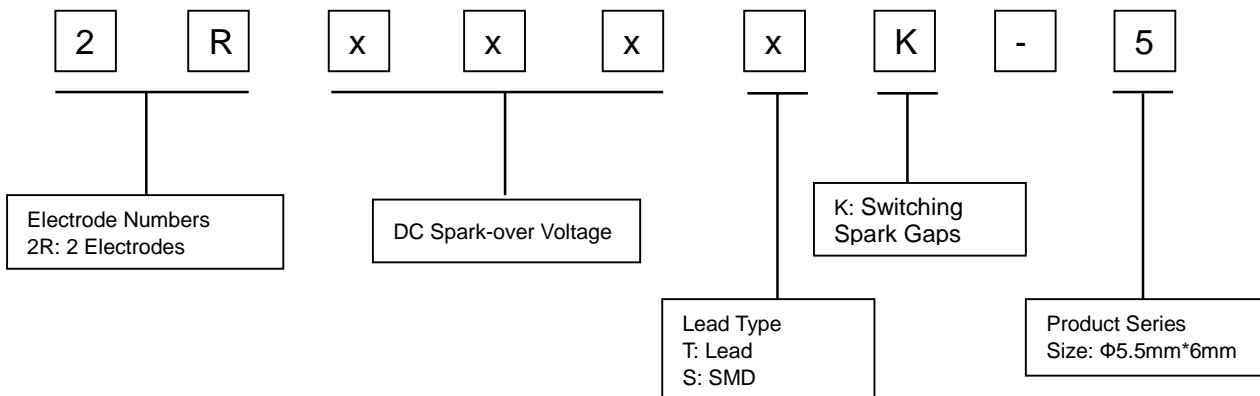

Electrical Characteristics

Part Number	DIP	2R230TK-5	2R250TK-5	2R300TK-5	2R350TK-5
	SMD	2R230SK-5	2R250SK-5	2R300SK-5	2R350SK-5
Initial Values					
Static Breakdown Voltage V_S @100V/S ¹⁾					
First ignition Value after 24 hours in darkness		<275 V	<300 V	<360 V	<420 V
Following Ignition Values		207~253 V	225~275 V	270~330 V	315~385 V
Electrical Life Time					
Breakdown Voltage V_B ²⁾					
First ignition Value after 24 hours in darkness		<285 V	<310 V	<370 V	<435 V
Following Ignition Values		196~265 V	215~290 V	255~350 V	300~405 V
Switching Operations @ +25°C		10 ⁵	10 ⁵	10 ⁵	10 ⁵
Breakdown Time		<50 ns	<50 ns	<50 ns	<50 ns
Maximum Switching Frequency		100 Hz	100 Hz	200 Hz	200 Hz
Test Circuit Parameters					
Open Circuit Voltage V_0		230 V _{AC}	350 V	400 V	450 V
Loading Resistance R		15 KΩ	10 KΩ	10 KΩ	10 KΩ
Discharge Capacitance C		2.2 μF	680 nF	680 nF	680 nF
Inductance L		10 μH	0.5 μH	0.5 μH	0.5 μH
Discharge Peak Current I_P		~300 A	~500 A	~500 A	~500 A

Part Number	DIP	2R380TK-5 ³⁾	2R400TK-5	2R450TK-5	2R470TK-5
	SMD	2R380SK-5 ³⁾	2R400SK-5	2R450SK-5	2R470SK-5
Initial Values					
Static Breakdown Voltage V_S @100V/S ¹⁾					
First ignition Value after 24 hours in darkness		<460 V	<480 V	<540 V	<560 V
Following Ignition Values		350~420 V	360~440 V	405~495 V	423~517 V
Electrical Life Time					
Breakdown Voltage V_B ²⁾					
First ignition Value after 24 hours in darkness		<460 V	<500 V	<560 V	<585V
Following Ignition Values		330~440 V	340~460 V	385~515 V	400~540 V
Switching Operations @ +25°C		10 ⁵	10 ⁵	10 ⁵	10 ⁵
Breakdown Time		<50 ns	<50 ns	<50 ns	<50 ns
Maximum Switching Frequency		200 Hz	200 Hz	200 Hz	200 Hz
Test Circuit Parameters					
Open Circuit Voltage V_0		500 V	520 V	580 V	600 V
Loading Resistance R		10 KΩ	10 KΩ	10 KΩ	10 KΩ
Discharge Capacitance C		680 nF	680 nF	680 nF	680 nF
Inductance L		0.5 μH	0.5 μH	0.5 μH	0.5 μH
Discharge Peak Current I_P		~500 A	~500 A	~500 A	~500 A



Part Number	DIP	2R500TK-5	2R550TK-5 ⁴⁾	2R600TK-5
	SMD	2R500SK-5	2R550SK-5 ⁴⁾	2R600SK-5
Initial Values				
Static Breakdown Voltage V_S @100V/S ¹⁾				
First ignition Value after 24 hours in darkness		<600 V	<680 V	<720 V
Following Ignition Values		450~550 V	510~630 V	540~660 V
Electrical Life Time				
Breakdown Voltage V_B ²⁾				
First ignition Value after 24 hours in darkness		<625 V	<710 V	<750 V
Following Ignition Values		425~575 V	485~655 V	510~690 V
Switching Operations @ +25°C		10^5	10^5	10^5
Breakdown Time		<50 ns	<50 ns	<50 ns
Maximum Switching Frequency		200 Hz	200 Hz	200 Hz
Test Circuit Parameters				
Open Circuit Voltage V_0		630 V	720 V	750 V
Loading Resistance R		13 K Ω	13 K Ω	13 K Ω
Discharge Capacitance C		470 nF	470 nF	470 nF
Inductance L		0.1 μ H	0.1 μ H	0.1 μ H
Discharge Peak Current I_P		~600 A	~600 A	~600 A
Insulation Resistance @100 V		> $10^8 \Omega$		
Capacitance @1MHz		<1 pF		
Marking, Red		RUILON xxx K X xxx -Nominal voltage K -Switching Spark Gaps X -Year of production		
Weight		~0.85g		
Operation and storage temperature		-40~+125°C		
Surface treatment		DIP -Nickel Plated SMD -Matte-tin plated		

¹⁾ At delivery AQL 0.65 level II, DIN ISO 2859

²⁾ Fig. 1

³⁾ 350 Marking

⁴⁾ 600 Marking

Test Circuit Fig. 1

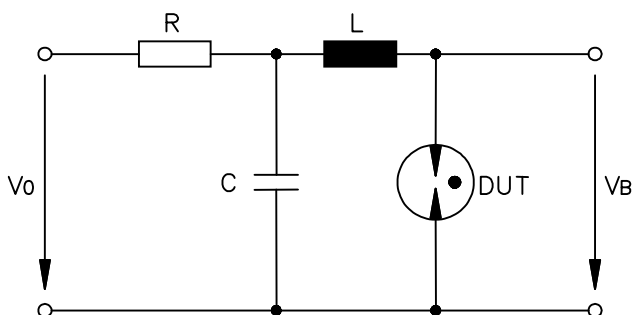

DUT Device Under Test
 V_B Breakdown Voltage
 V_0 , R , L and C Parameters See above table



Dimensions (Unit: mm/inch)

DIP Series (2RxxxTK-5)

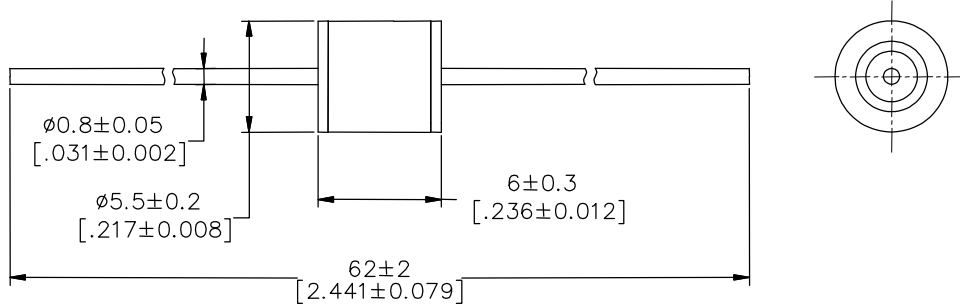

SMD Series (2RxxxSK-5)

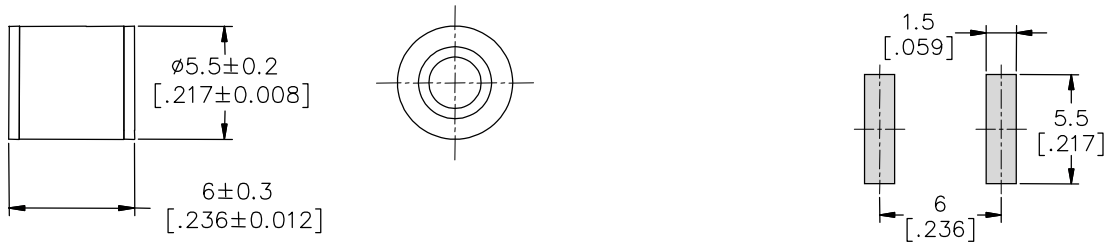

Recommended Soldering Pad Layout

Packaging Information (Unit: mm/inch)

Axial Packaging (Bulk)

Plastic Tray

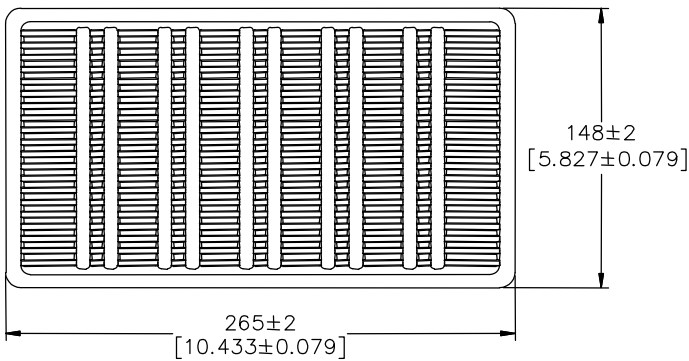

Inner box

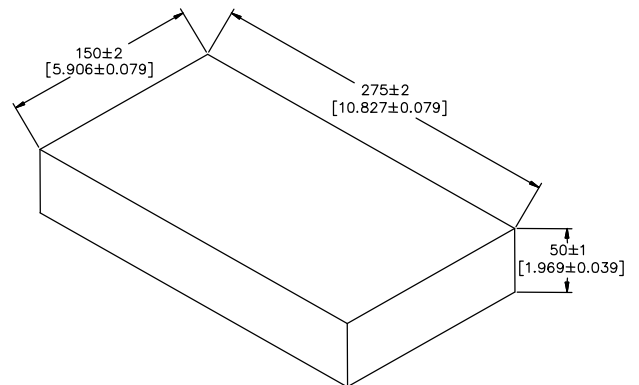

Packaging Quantity:

100 PCS per Plastic Tray

5 Plastic Trays per inner box

500 PCS per inner box



SMD Packaging (Tape & Reel)

Tape

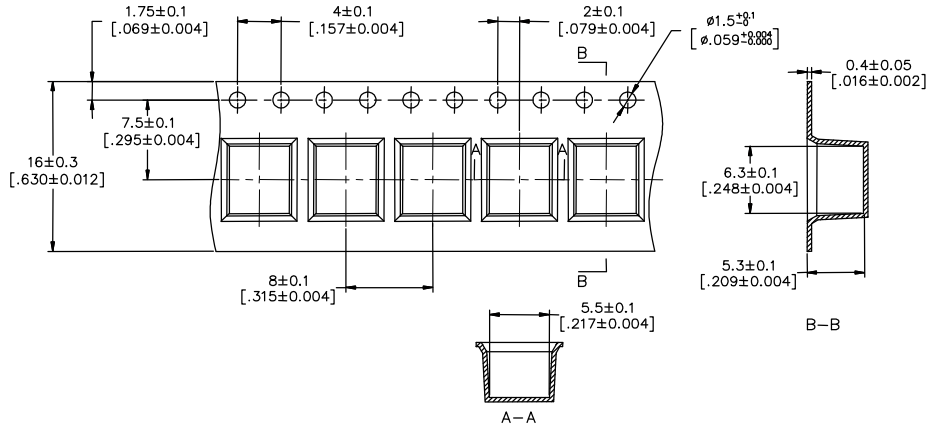

Reel

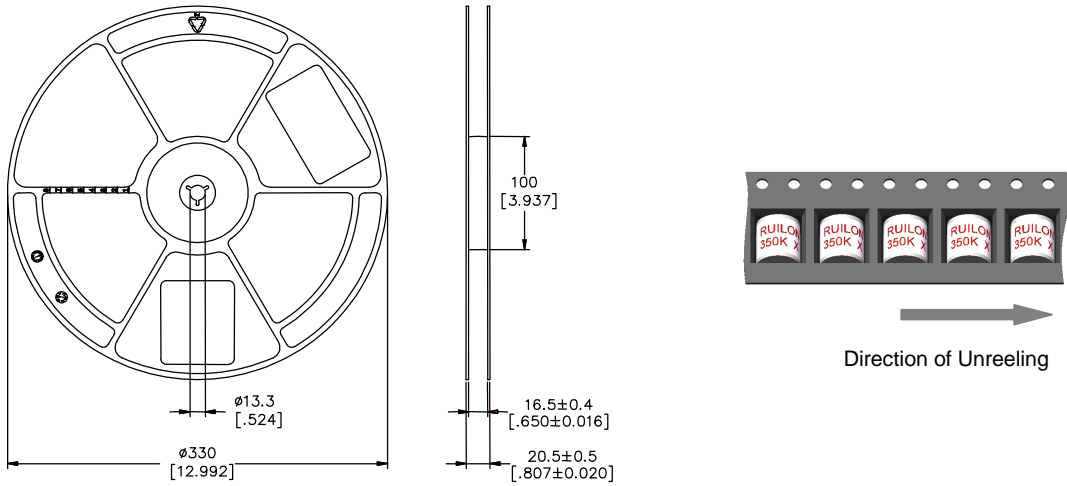

Inner box

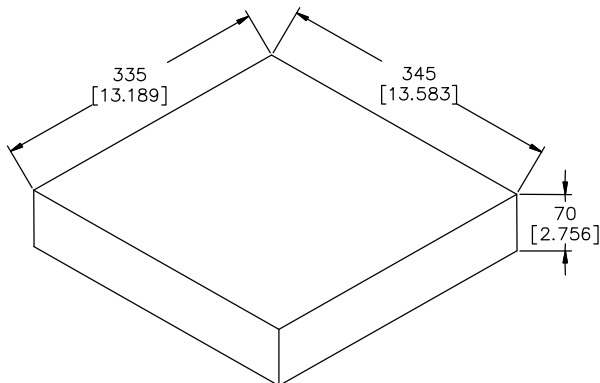

Packaging Quantity:

- 1,000 PCS per reel (13")
- 3 reels per inner box
- 3,000 PCS per inner box



Basic Application Circuit

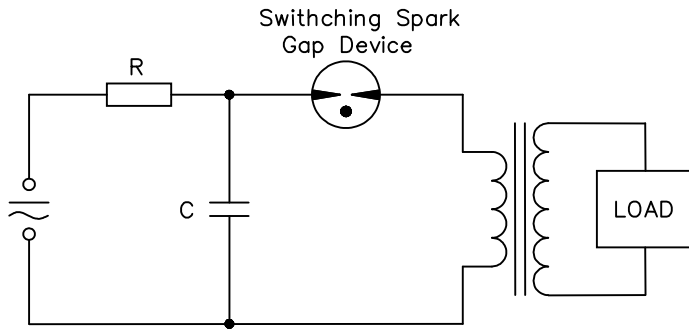

Soldering Parameters - Wave soldering (Thru-Hole Devices)

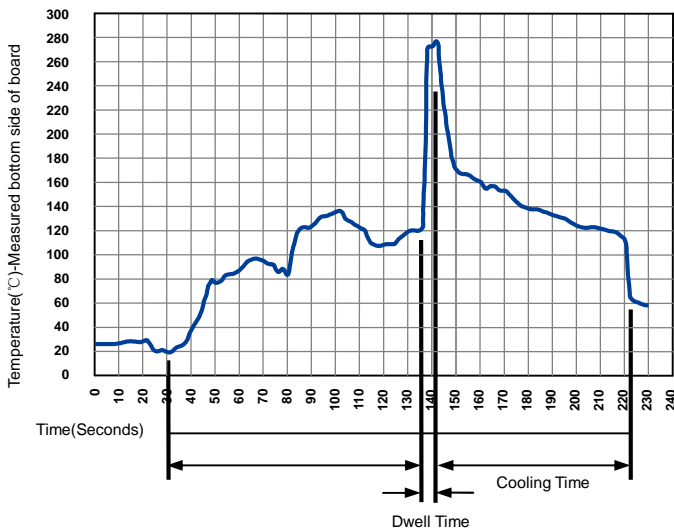

Wave Soldering Condition		Pb-Free assembly
Preheat	Temperature Min	100°C
	Temperature Max	150°C
	Time (Min to Max)	60-180 Seconds
Solder Pot Temperature		280°C Max
Solder Dwell Time		2-5 Seconds

Soldering Parameters - Reflow Soldering (Surface Mount Devices)

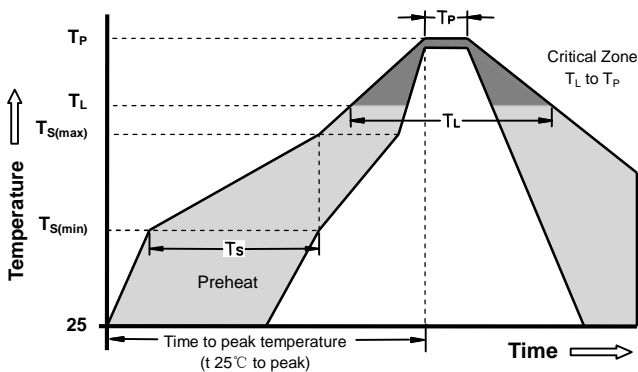

Reflow Condition		Pb - Free assembly
Preheat	-Temperature Min ($T_{s(min)}$)	150°C
	-Temperature Max ($T_{s(max)}$)	200°C
	- Time (min to max) (t_s)	60 -180 Seconds
Average ramp up rate (Liquids Temp T_L to peak)		3°C/second max
$T_{s(max)}$ to T_L - Ramp-up Rate		5°C/second max
Reflow	- Temperature (T_L) (Liquids)	217°C
	- Time (min to max) (t_s)	60 -150 Seconds
Peak Temperature (T_P)		260 +0/-5°C
Time within 5°C of actual peak Temperature (t_p)		10 - 30 Seconds
Ramp-down Rate		6°C/second max
Time 25°C to peak Temperature (T_P)		8 minutes Max
Do not exceed		260°C

