

Description

2R-8 Gas Discharge Tubes (GDT) series provides high levels of protection against fast rising transients caused by lightning disturbances. Offered in a miniature surface mount package, it has a surge rating of 10KA/5KA/3KA 8/20 μ s.

2R-8 GDTs are high voltage (1000-5000V) components designed for surge protection and high isolation applications. It is also suitable for applications for which bias voltage or signal levels of several hundred volts are normally present. 2R-8 GDTs can be used in conjunction with MOVs (Metal Oxide Varistors) to provide superior protection performance for AC applications.

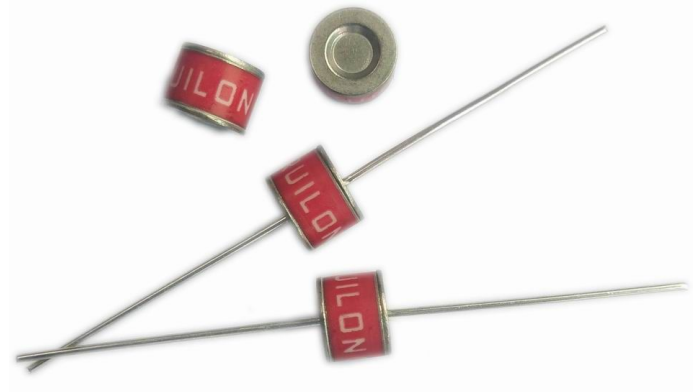

Electrical symbol

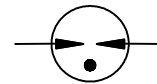

Features

- I Voltage Ranges 1000V to 5000V
- I Excellent response to fast rising transients
- I 8/20 μ s Impulse current capability: 10KA/5KA/3KA
- I Non-Radioactive
- I Ultra Low capacitance (<1.5pF)
- I Lead-free compliant
- I RoHS and REACH compliant
- I UL 1449 Recognized: E479668
- I Size: Φ 8mm*6mm
- I Storage and operational temperature: -40~+125 $^{\circ}$ C

Applications

- | | |
|-----------------------------|--------------------|
| Automotive: | Others: |
| I On-board chargers | I LED lighting |
| I Vehicle charging stations | I Power supply |
| | I Photovoltaic |
| | I Air conditioning |

Part Number Code

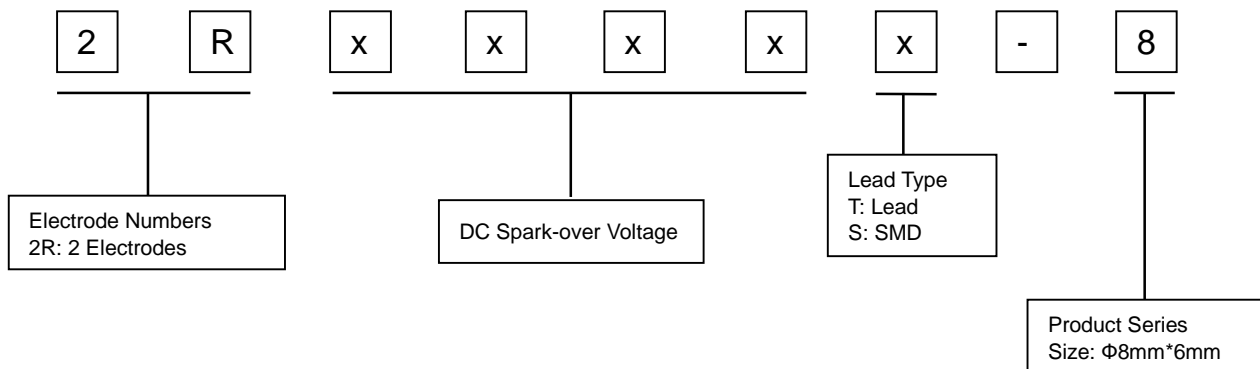

Electrical Characteristics

Part Number		DC Spark-over Voltage ¹⁾²⁾ @100V/S	Impulse Spark-over Voltage		Insulation Resistance ³⁾	Capacitance @1MHz	Glow Voltage @10mA	Arc Voltage @1A	AC withstand voltage @5mA 1Min	Life Ratings		
			100V/μS	1KV/μS						Impulse Discharge Current @8/20μS		AC Discharge Current @50Hz 1S
			Max	Max						Min	Max	Nominal ±5 times
DIP	SMD	V	V	V	GΩ	pF	V	V	V	KA	KA	A
2R1000T-8	2R1000S-8	1000±20%	1600	1800	1	1.5	160	15	500	10	15	10
2R1200T-8 ⁴⁾	2R1200S-8 ⁴⁾	1200±20%	1800	2000	1	1.5	160	15	600	10	15	10
2R1400T-8	2R1400S-8	1400±20%	2200	2400	1	1.5	235	18	700	5	10	5
2R1500T-8 ⁴⁾	2R1500S-8 ⁴⁾	1500±20%	2300	2500	1	1.5	235	18	750	5	10	5
2R1600T-8	2R1600S-8	1600±20%	2400	2600	1	1.5	235	18	800	5	10	5
2R1800T-8 ⁴⁾	2R1800S-8 ⁴⁾	1800±20%	2600	2800	1	1.5	235	18	900	5	10	5
2R2000T-8	2R2000S-8	2000±20%	2800	3000	1	1.5	260	30	1000	5	10	5
2R2400T-8	2R2400S-8	2400±20%	3200	3400	1	1.5	260	30	1200	5	10	5
2R2500T-8	2R2500S-8	2500±20%	3300	3500	1	1.5	260	30	1300	5	10	5
2R2700T-8	2R2700S-8	2700±20%	3500	3700	1	1.5	260	30	1400	5	10	5
2R3000T-8	2R3000S-8	3000±20%	3700	3900	1	1.5	260	30	1600	5	10	5
2R3500T-8	2R3500S-8	3500±20%	4300	4500	1	1.5	260	30	1800	5	10	5
2R3600T-8	2R3600S-8	3600±20%	4400	4600	1	1.5	260	30	1900	5	10	5
2R4000T-8	2R4000S-8	4000±20%	5000	5500	1	1.5	280	35	2100	3	5	3
2R4500T-8	2R4500S-8	4500±20%	5500	6000	1	1.5	280	35	2300	3	5	3
2R5000T-8	2R5000S-8	5000±20%	6000	6500	1	1.5	280	35	2600	3	5	3
Glow to Arc transition Current.....						~0.5A						
Weight.....						DIP ~1.2g SMD ~0.95g						
Operation and storage temperature.....						-40~+125°C						
Climatic category (IEC 60068-1).....						40/125/21						
Marking, red negative.....						RUILON XXX Y XXX -Nominal voltage Y -Year of production						
Surface treatment.....						DIP -Nickel Plated SMD -Matte-tin plated						

¹⁾ At delivery AQL 0.65 level II, DIN ISO 2859.

²⁾ In ionized mode.

³⁾ Insulation Resistance Measuring Voltage at DC 100V.

⁴⁾ No UL 1449 Recognized.

Terms in accordance with ITU-T Rec. K.12, IEC 61643-311, GB/T 9043.

Dimensions (Unit: mm/inch)

DIP Series (2RxxxxT-8)

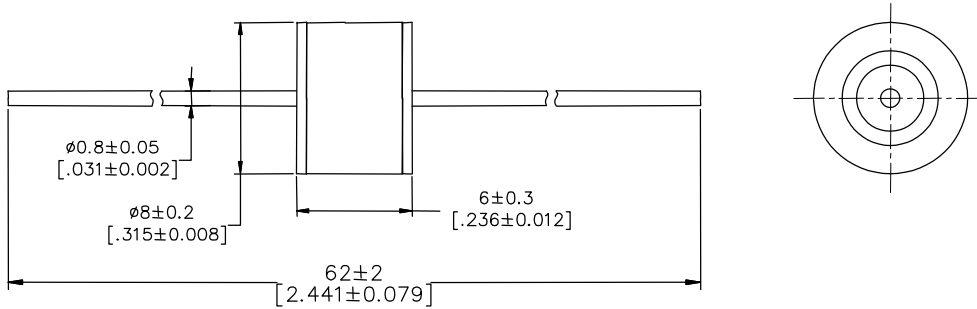

SMD Series (2RxxxxS-8)

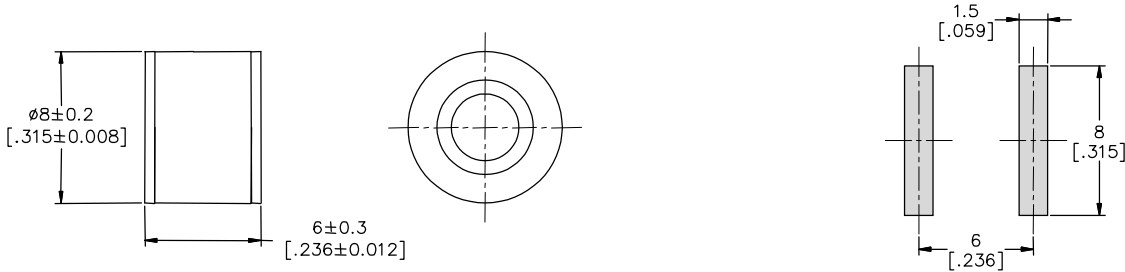

Recommended Soldering Pad Layout

Packaging Information (Unit: mm/inch)

Axial Packaging (Bulk)

Plastic Tray

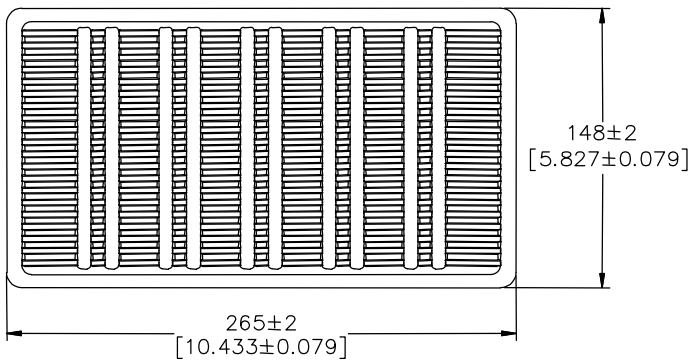

Inner box

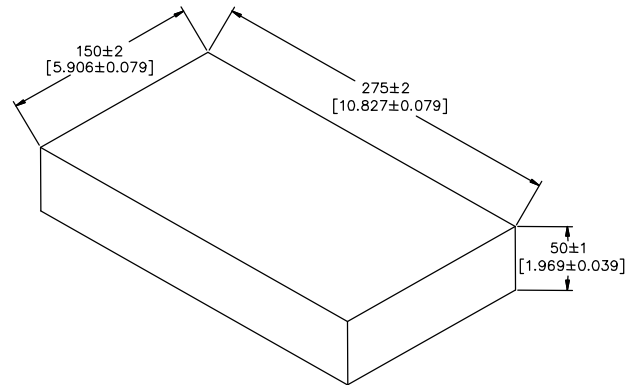

Packaging Quantity:

100 PCS per Plastic Tray

5 Plastic Trays per inner box

500 PCS per inner box

Axial Packaging (Tape & Reel)

Tape

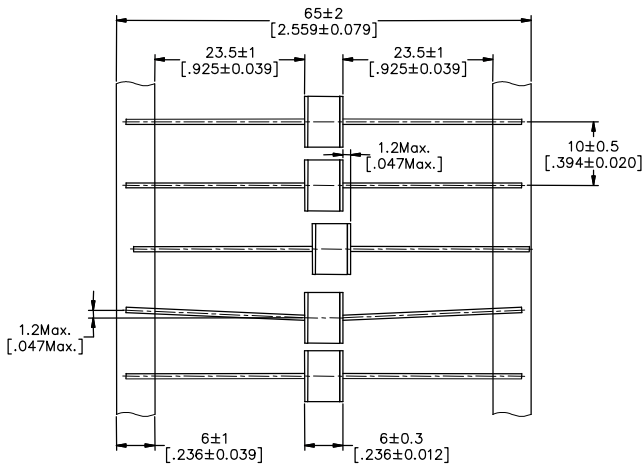

Reel

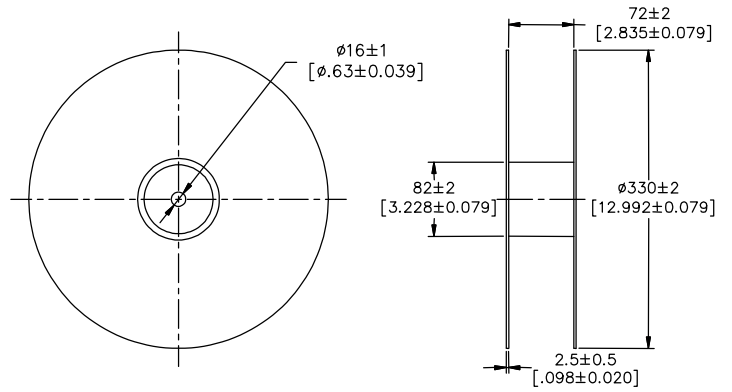

Packaging Quantity:

800 PCS per reel

SMD Packaging (Tape & Reel)

Tape

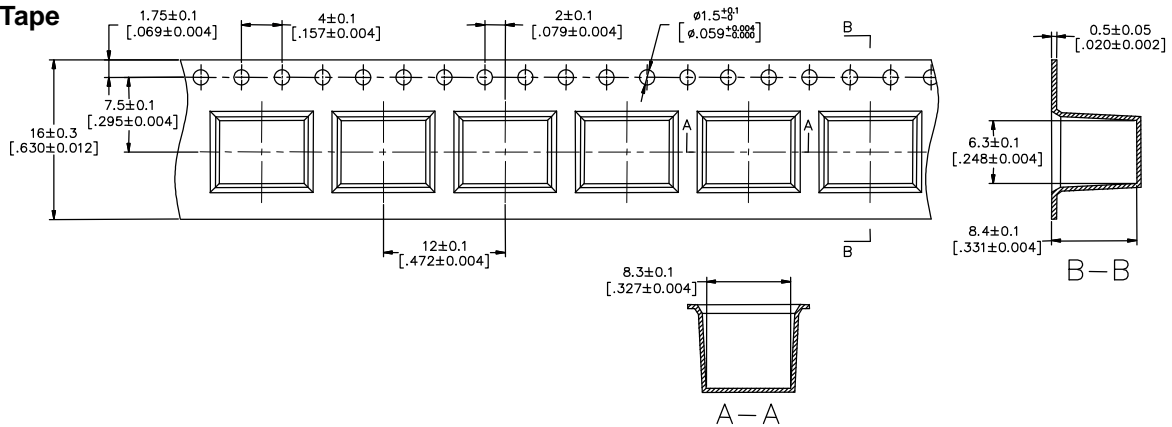

Reel

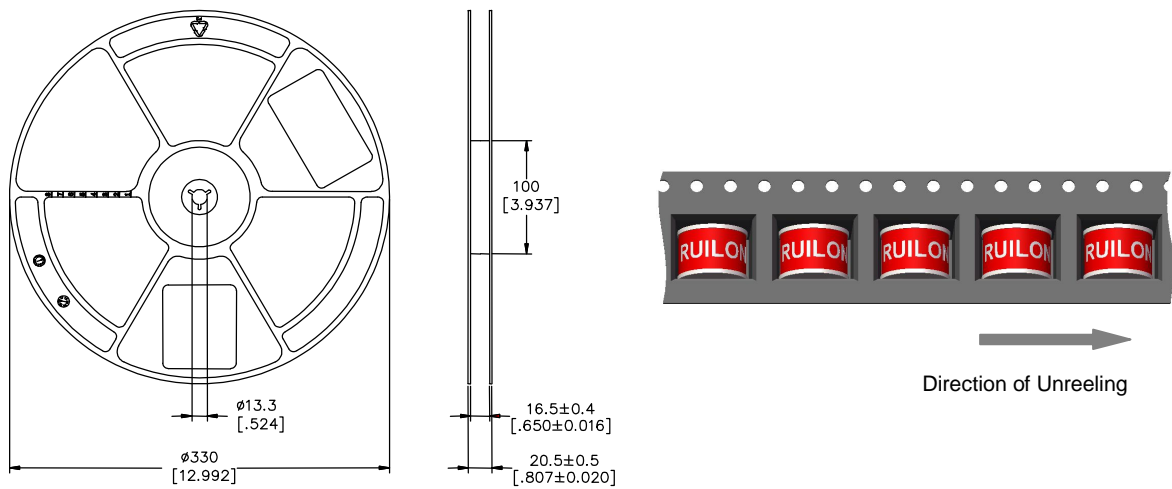

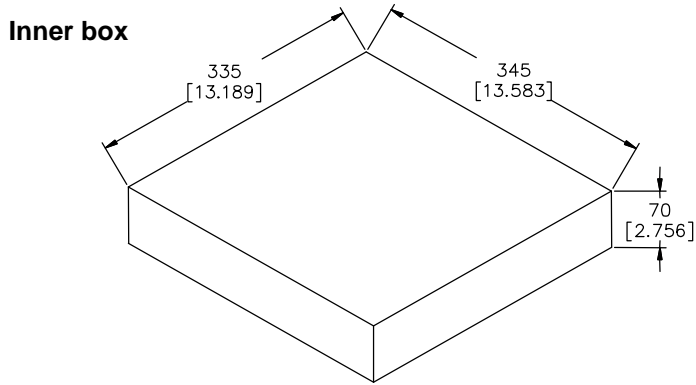

Packaging Quantity:

500 PCS per reel (13")

3 reels per inner box

1,500 PCS per inner box

Soldering Parameters - Wave soldering (Thru-Hole Devices)

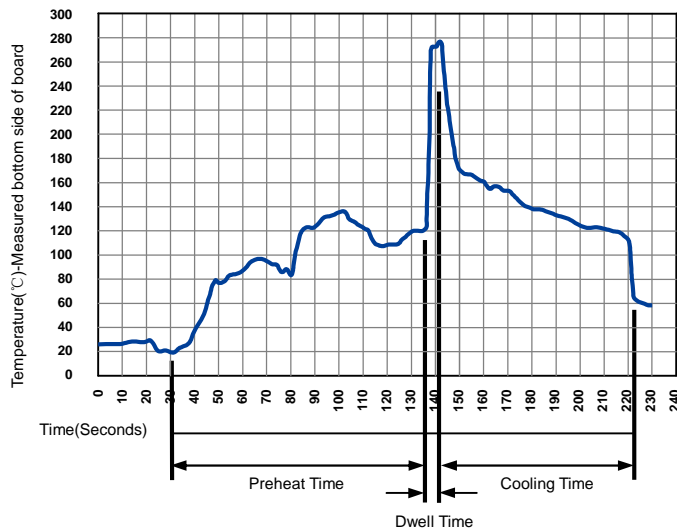

Wave Soldering Condition		Pb-Free assembly
Preheat	Temperature Min	100°C
	Temperature Max	150°C
	Time (Min to Max)	60-180 Seconds
Solder Pot Temperature		280°C Max
Solder Dwell Time		2-5 Seconds

Soldering Parameters - Reflow Soldering (Surface Mount Devices)

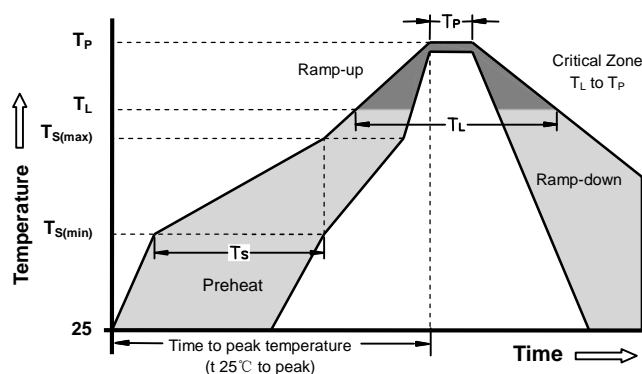

Reflow Condition		Pb - Free assembly
Preheat	-Temperature Min ($T_{s(min)}$)	150°C
	-Temperature Max ($T_{s(max)}$)	200°C
	- Time (min to max) (t_s)	60 -180 Seconds
Average ramp up rate (Liquids Temp T_L to peak)		3°C/second max
$T_{S(max)}$ to T_L - Ramp-up Rate		5°C/second max
Reflow	- Temperature (T_L) (Liquids)	217°C
	- Time (min to max) (t_s)	60 -150 Seconds
Peak Temperature (T_P)		260 +0/-5°C
Time within 5°C of actual peak Temperature (t_p)		10 - 30 Seconds
Ramp-down Rate		6°C/second max
Time 25°C to peak Temperature (T_P)		8 minutes Max
Do not exceed		260°C